

YANMAR DIESEL ENGINE

PARTS CATALOG

● パーツカタログ

000Y00R4510

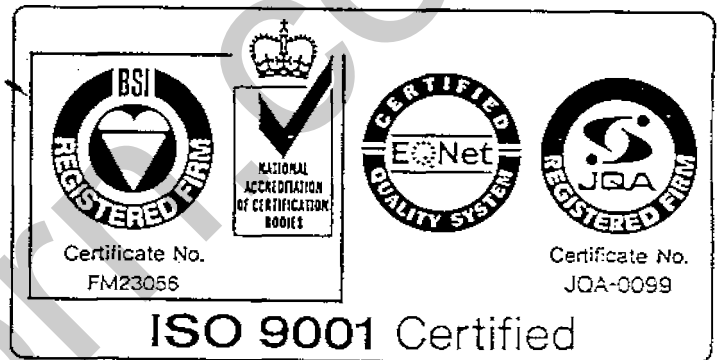

MODEL

3TNE68-SA, G1A, G2A

⊙ : STD ○ : Option × : Not applicable

Types of P.T.O			3TNE68		
			SA	G1A	G2A
Flywheel Housing	SAE # 5 Standard for Clutch No.7-1/2	A	⊙	×	×
	SAE # 5 Standard for SAE Generator	B	○	⊙	⊙
	Semi SAE # 4 (Width 105mm)	C	×	×	×
	Semi SAE # 5 (with 80mm)	D	○	×	○
Back Plate		E	○	×	○

This parts catalogue covers all specificasion.

How to read this Parts Catalog.

- Parts mentioned in this Parts Catalog may not necessarily be standard equipping parts.
- Parts change may be made without prior notice.
- Form of this Parts Catalog.

REF.	LEV.	PART NO.	DESCRIPTION	(A)	(D)	(E)	(F)	I	P	U	A	R
1	1	729595-51390	FUEL INJECTION PUMP	1	1	1	1	1	1	1	1	1
1-1	1	729595-51391	FUEL INJECTION PUMP	1	1	1	1	1	1	1	1	N
3	3	26022-060162	SCREW M 6X 16	9	9	9	9	9	9	9	9	9
3-1	3	26022-060162	SCREW M 6X 16	4	4	4	4	4	4	4	4	K
4	4	129470-51040	CAMSHAFT	1	1	1	1	1	1	1	1	1
5	5	122710-51050	BEARING, ROLLER	2	2	2	2	2	2	2	2	2
6	6	129470-51050	RETAINER	1	1	1	1	1	1	1	1	1
7	7		OIL	1	1	1	1	1	1	1	1	1

REMARKS (E) (F)
 1) 729595-51391, 4JH-DT, 4JH-DT2, 4JH-DT2Z, 4JH-DT2ZY, 4JH-DT2ZY PART, TO E/00155, 4JH-DT, 4JH-DT2
 E/00155 277110 129470 51050 51040 51390 51391
 Y023466

① Ref. No.

The Ref. No. in the list may not be accord with the Ref. No. on illustration.

(Ex.) Illustration No. List head No.

1 1 (Before change) → 1-1 (After change)

When interchangeable symbol N, R and K, illustrations for the new parts are sometimes omitted.

② Lev. (Level)

Indication and Meaning of Level

Level: Hereunder is given the relation among the number of dots (·), the level and the nominal parent-child relationship.

- Parent parts (Assembly parts)
- Child parts included in "•" (Semi-Assembly parts, component parts of Assembly parts.)
- Child parts included in "••", Grand-child parts in terms of "•". (Component parts of Semi-Assembly parts.)

Note) A part of non-sale parts are illustrated but not listed.

③ Change Mark

Change Mark "I" is given to the part for which a design change was made at this time. The design change was not shown in the last published Parts Catalog.

④ Interchangeability Mark

In the case where a part change took place, one of the following interchangeability marks is indicated for that part.

Symbol	Interchangeability	Contents note
N	Old NEW	New Part is interchangeable for Old Part but not interchangeable conversely.
Q	Old NEW	New Part is not interchangeable for Old Part but interchangeable conversely.
R	Old NEW	New Part is interchangeable for Old Part and vice versa.
S	Old NEW	New Part is not interchangeable for Old Part and vice versa.
W		Part newly added.
Z		Part discontinued.
F		Not interchangeable single part but interchangeable by set of the related parts.
K		Changed only in quantity used.

⑤ Effective Machine No.

When a part is changed, Effective Machine No. of a Model for which the part is applicable is indicated in each column of (A) - (F).

Product symbol	Product No.	Product symbol	Product No.
C	Clutch No., Copressor No.	M	Machine No.
D	Drive No.	T	Tractor No.
E	Engine No.	Note1) ※	Date

Note1) Date may follow the symbol in some cases. (Ex.) ※1990. 02

Note2) As far as engine models shown by "XXX" are concerned, the modification of the parts could not be predicted or the engine models themselves could not be identified.

Note3) (A=E00185) means that the design change on the part has been effective for the model at the column (A) (in this case, for 4JH-DT) on and from E (Engine Serial Number) 00185.

⑥ Remarks Mark

Figures or alphabets (Symbols) are entered in the remark column.

The comments (remarks) on the pertinent parts are indicated in the lower part of the list by the same symbols as those stated above.

451D)

 +-----+
 | 1801 |
 +-----+

 *
 * (001) 3TNE68-SA,G1A,G2A *
 *

GROUP NO.	GROUP NAME	LOCATION NO.
1	CYLINDER BLOCK	1802
2	GEAR HOUSING	1803
3	FLYWHEEL HOUSING & OIL SUMP	1804
4	CYLINDER HEAD & BONNET	1805
5	SUCTION MANIFOLD & AIR CLEANER	1806
6	EXHAUST MANIFOLD & SILENCER	1807
7	CAMSHAFT & DRIVING GEAR	1808
8	CRANKSHAFT & PISTON	1809
9	LUB.OIL SYSTEM	1810
10	COOLING WATER SYSTEM	1811
11	RADIATOR	1812
12	FUEL INJECTION PUMP	1813
13	GOVERNOR	1814
14	FUEL INJECTION VALVE	1816
15	FUEL FILTER	1C01
16	ENGINE CONTROL DEVICE	1C02
17	STARTING MOTOR	1C03
18	GENERATOR	1C04
19	PANEL	1C05
20	GASKET SET	1C06

1. CYLINDER BLOCK

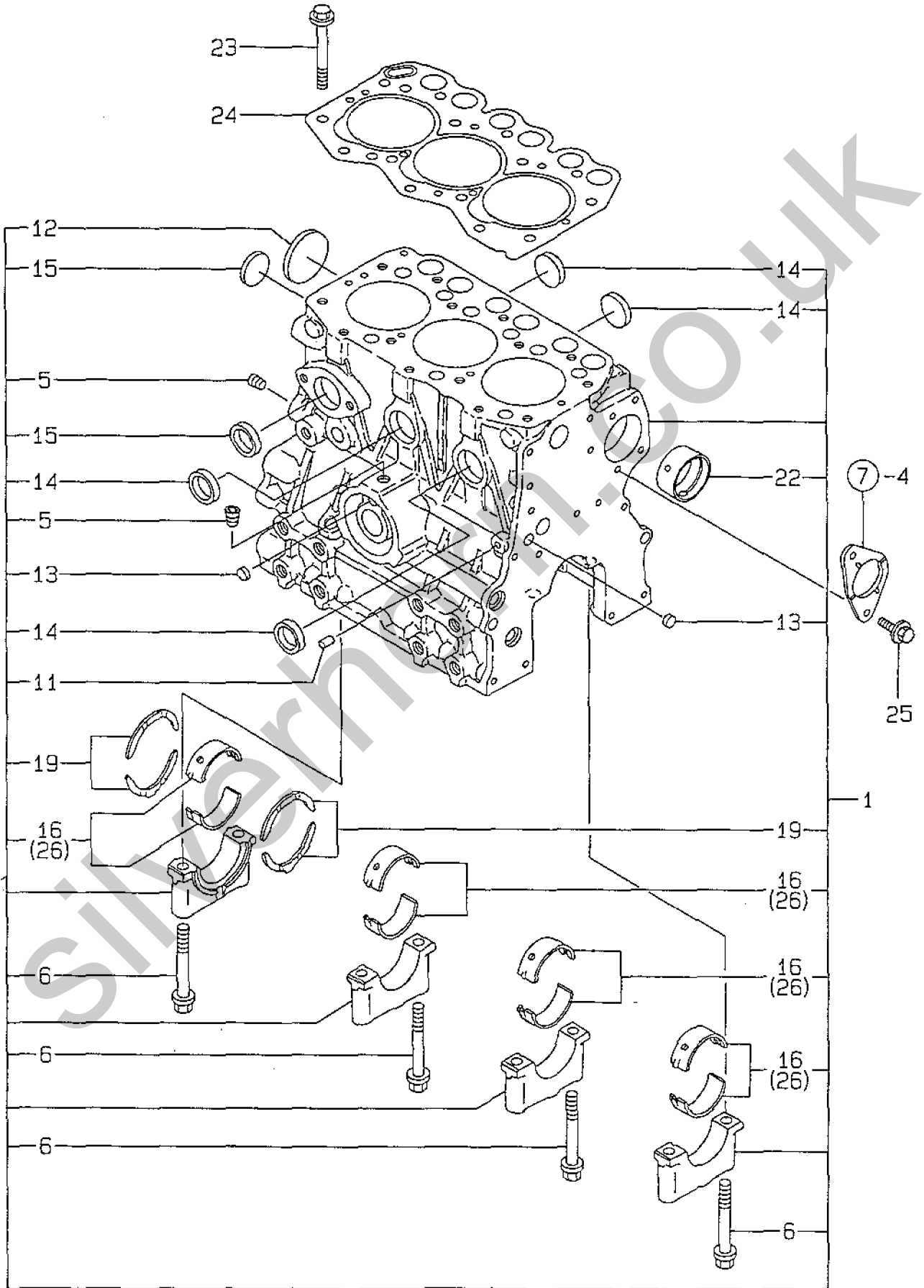

(1) CYLINDER BLOCK

+-----+
I 1B02 I
I(1B01)I
+-----+
Y00R4510

(A)=3TNE68-SA (D)=
(B)=3TNE68-G1A (E)=
●(C)=3TNE68-G2A (F)=

REF. NO.	LEV. 0	PART NO.	DESCRIPTION	-----Q'TY-----						I P/U A R
				(A)	(B)	(C)	(D)	(E)	(F)	
1	.	719265-01560	BLOCK ASSY, CYLINDER	1	1	1				
5	..	124060-01050	PLUG PT1/8	2	2	2				
6	..	119260-02020	BOLT	8	8	8				
11	..	27221-060100	PLUG 6X10	1	1	1				
12	..	27231-400000	PLUG 40	1	1	1				
13	..	27241-100000	PLUG 10	2	2	2				
14	..	27241-250000	PLUG 25	4	4	4				
15	..	27241-300000	PLUG 30	2	2	2				
16	..	119260-02800	MAIN BEARING	4	4	4				
19	..	119260-02930	THRUST BEARING	2	2	2				
22	..	119260-02410	BUSH, CAMSHAFT	1	1	1				
23	.	119260-01200	BOLT, CYL.HEAD	14	14	14				
24	.	119265-01340	GASKET, CYL. HEAD	1	1	1				(G)
25	.	26106-060122	BOLT M 6X 12 PLATED	2	2	2				
26	.	719260-02870	MAIN BEARING US=0.25	4	4	4				(1)

----- REMARKS -----

I(1) UNDER-SIZE(U.S=0.25)PART.
I(G) THESE PARTS ARE SOLD BY FIG.20,
I REF.NO.1.

2. GEAR HOUSING

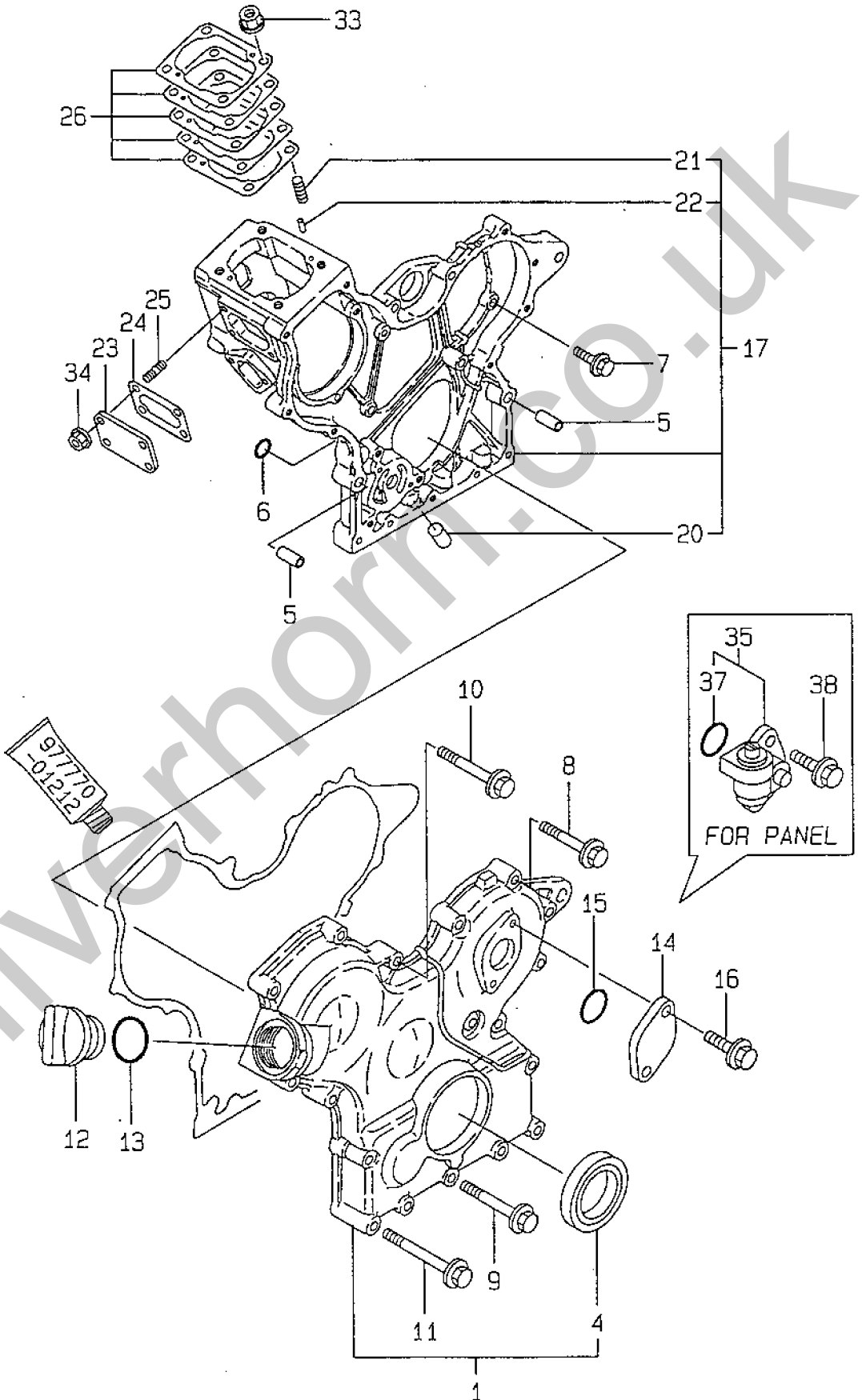

(2) GEAR HOUSING

(A)=3TNE68-SA (D)=
 (B)=3TNE68-61A (E)=
 (C)=3TNE68-G2A (F)=

1803 I
 (1801) I
 Y00R4510

REF. NO.	LEV. 0	PART NO.	DESCRIPTION	Q'TY----- I P/U A R					
				(A)	(B)	(C)	(D)	(E)	(F)
1	.	119260-01590	COVER ASSY, GEAR CASE	1	1	1			
4	..	119620-01800	SEAL HTC456208, OIL	1	1	1			
5	.	119660-01911	PIPE, KNOCK	4	4	4			
6	.	24311-000120	O-RING 1A P 12.0	2	2	2			(G)
7	.	26106-060162	BOLT M 6X 16 PLATED	5	5	5			
8	.	26106-060302	BOLT M 6X 30 PLATED	5	5	5			
9	.	26106-060402	BOLT M 6X 40 PLATED	3	3	3			
10	.	26106-060502	BOLT M 6X 50 PLATED	4	4	4			
11	.	26106-060652	BOLT M 6X 65 PLATED	6	6	6			
12	.	124160-01751	CAP, LUB.OIL SUPPLY	1	1	1			
13	.	24311-000320	O-RING 1A P-32.0	1	1	1			(G)
14	.	121023-01550	COVER, BLIND	1	1	1			
15	.	24341-000240	O-RING 1A S-24.0	1	1	1			(G)
16	.	26106-060182	BOLT M 6X 18 PLATED	2	2	2			
17	.	119260-01490	HOUSING ASSY, GEAR	1	1	1			
20	..	119260-01510	PLUG	1	1	1			
21	..	121450-01560	STUD M 8X 22	4	4	4			
22	..	22351-040010	SPRING PIN 4X10	2	2	2			
23	.	119660-01551	COVER	1	1	1			
24	.	119660-01562	GASKET, (NON-ASB.)	1	1	1			(G)
25	.	119660-01570	STUD M6X12	4	4	4			
26	.	119623-01950	SHIM PACK	1	1	1			
33	.	194990-22050	NUT W/WASHER 8	4	4	4			
34	.	26366-060002	NUT M 6	4	4	4			
35	.	129150-91400	GEAR UNIT, TACHOMETER	1	1	1			(1)
37	..	24341-000240	O-RING 1A S-24.0	1	1	1			(1)
38	.	26106-060162	BOLT M 6X 16 PLATED	2	2	2			(1)

REMARKS

1(1) FOR PANEL.
 1(G) THESE PARTS ARE SOLD BY FIG.20,
 1 REF.NO.1.

3. FLYWHEEL HOUSING & LUB. OIL SUMP

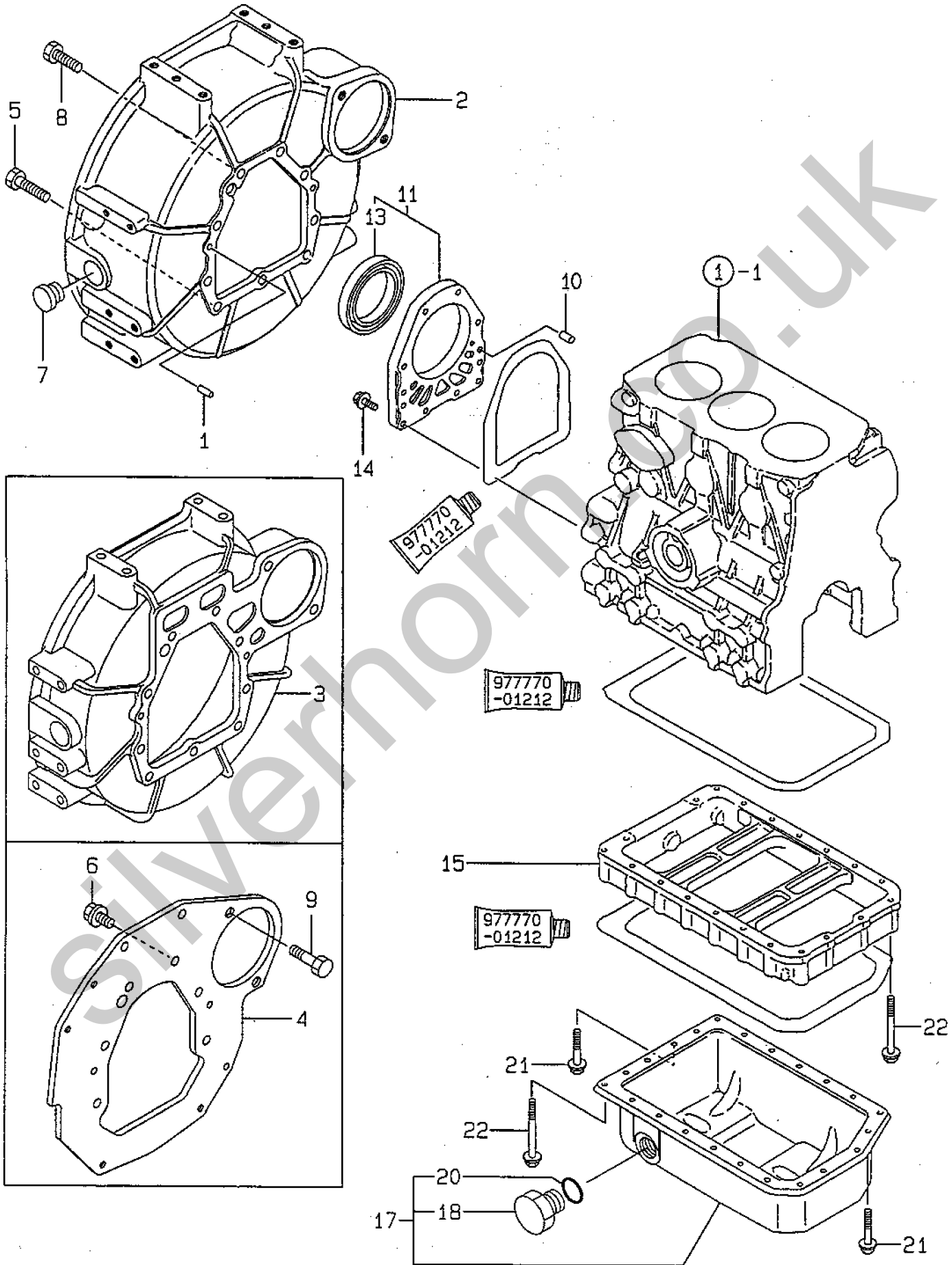

(3) FLYWHEEL HOUSING & OIL SUMP

(A)=3TNE68-SA (D)=

(B)=3TNE68-G1A (E)=

(C)=3TNE68-G2A (F)=

1 1B04 I
 1(1B01)I
 +-----+
 YOOR4510

REF. NO.	LEV. 0	PART NO.	DESCRIPTION	-----Q'TY-----						I P/U A R
				(A)	(B)	(C)	(D)	(E)	(F)	
1	.	129100-01580	PARALLEL PIN 8X16	2	2	2				(1)
2	.	119280-01600	FLANGE, MOUNTING	1	1	1				(2)
3	.	119600-01600	HOUSING, FLYWHEEL	1		1				(3)
4	.	119621-01611	REAR PLATE	1		1				(4)
5	.	121120-01620	BOLT M 10X 28	3	3	3				(5)
6	.	26116-100202	BOLT M10X 20 PLATED	8		8				(4)
7	.	119620-01750	CAP, FLYWHEEL COVER	1	1	1				(5)
8	.	26206-100252	BOLT M10X25	6	6	6				(5)
9	.	119620-01621	STUD, STARTER	2		2				(4)
10	.	119620-01620	PARALLEL PIN 6X10	2	2	2				
11	.	119660-01640	CASE ASSY, OIL SEAL	1	1	1				
13	..	124085-02220	SEAL, OIL	1	1	1				
14	.	26106-060222	BOLT M 6X 22 PLATED	10	10	10				
15	.	119454-01721	SPACER, OIL SUMP	1	1	1				
17	.	119260-01770	SUMP ASSY, OIL	1	1	1				
18	..	121400-01640	PLUG M16	1	1	1				
20	..	24311-000180	O-RING 1A P-18.0	1	1	1				(6)
21	.	26106-060102	BOLT M 6X 10 PLATED	3	3	3				
22	.	26106-060452	BOLT M 6X 45 PLATED	20	20	20				

REMARKS

- (1) SAE GENE/SAE CLUTCH(FOR STD)/ SEMI SAE#5/BACK PLATE FOR -SA, SAE GENE(FOR STD) FOR -G1A, SAE GENE(FOR STD)/SEMI SAE#5/BACK PLATE FOR -G2A. STD) FOR -G1A,SAE GENE(FOR STD)/ SEMI SAE#5 FOR -G2A.
- (2) FOR SAE GENE(-G1A,G2A FOR STD), SAE CLUTCH(FOR STD) FOR -SA.
- (3) FOR SEMI SAE#5.
- (4) FOR BACK PLATE.
- (5) SAE GENE/SAE CLUTCH(FOR STD)/ SEMI SAE#5 FOR -SA,SAE GENE(FOR
- (6) THESE PARTS ARE SOLD BY FIG.20, REF.NO.1.

4. CYLINDER HEAD & BONNET

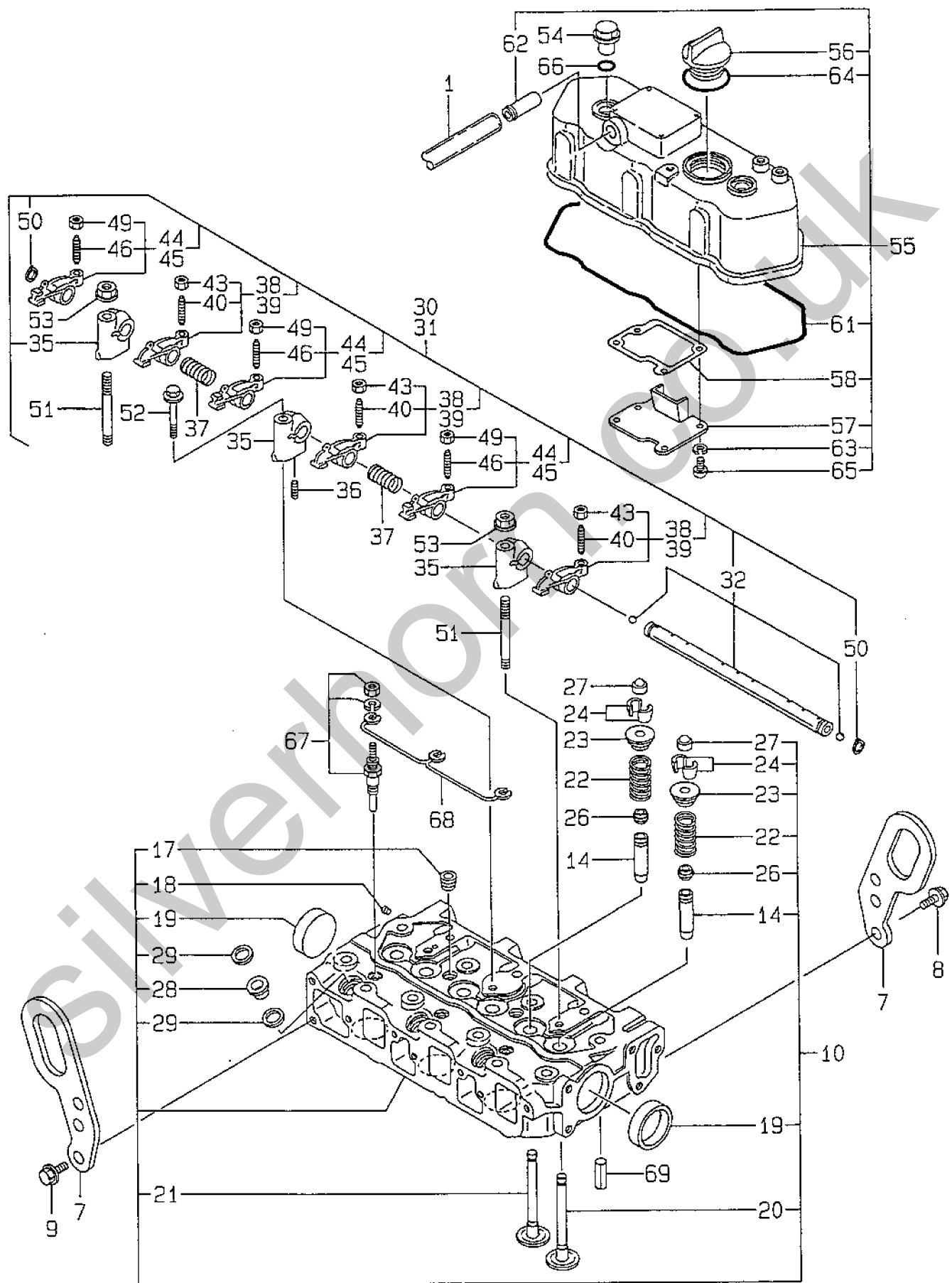

(4) CYLINDER HEAD & BONNET

(A)=3TNE68-SA (D)=
 (B)=3TNE68-G1A (E)=
 (C)=3TNE68-G2A (F)=

+-----+
 I 1B05 I
 I(1B01)I
 +-----+
 Y00R4510

REF. NO.	LEV. 0	PART NO.	DESCRIPTION	-----Q'TY----- I P/U A R					
				(A)	(B)	(C)	(D)	(E)	(F)
1	.	23065-120500	PIPE, VINYL 12X 500	1	1	1			
7	.	119260-07900	LIFTER, ENGINE	2	2	2			
8	.	26106-080142	BOLT M 8X 14 PLATED	1	1	1			
9	.	26106-080142	BOLT M 8X 14 PLATED	2	2	2			
10	.	119265-11700	HEAD ASSY, CYLINDER	1	1	1			
14	..	119260-11800	GUIDE, VALVE	6	6	6			(1)
17	..	23871-020000	PLUG PT1/4, SCREW	2	2	2			
18	..	27221-050080	PLUG 5X 8	1	1	1			
19	..	27241-350000	PLUG 35	2	2	2			
20	..	119260-11100	VALVE, SUCTION	3	3	3			
21	..	119260-11110	VALVE, EXHAUST	3	3	3			
22	..	114250-11120	SPRING, VALVE	6	6	6			
23	..	114250-11180	RETAINER, SPRING	6	6	6			
24	..	714250-11570	COTTER ASSY	6	6	6			
26	..	119260-11340	SEAL, VALVE STEM	6	6	6			(G)
27	..	119260-11370	CAP, VALVE	6	6	6			
28	..	119600-11450	PROTECTOR, NOZZLE	3	3	3			(G)
29	..	119600-11460	GASKET, NOZZLE	6	6	6			(G)
30	.	119260-11200	SUPPORT ASSY, ARM	1		1			
31	.	119489-11200	SUPPORT ASSY, ARM		1				
32	..	119260-11240	SHAFT ASSY, ARM	1	1	1			
35	..	119260-11260	SUPPORT, ROCKER ARM	3	3	3			
36	..	119260-11270	SCREW	1	1	1			
37	..	119260-11280	SPRING	2	2	2			
38	..	719260-11650	ARM ASSY, ROCKER	3		3			
39	..	719489-11650	ARM ASSY, ROCKER		3				
40	...	105010-11230	SCREW, VALVE	3	3	3			
43	...	26756-060002	LOCK NUT M 6 PLATED	3	3	3			
44	..	719260-11660	ARM ASSY, ROCKER	3		3			
45	..	719489-11660	ARM ASSY, ROCKER		3				
46	...	105010-11230	SCREW, VALVE	3	3	3			
49	...	26756-060002	LOCK NUT M 6 PLATED	3	3	3			
50	..	22242-000100	CIRCLIP 10	2	2	2			
51	.	119620-11350	STUD	2	2	2			
52	.	26106-080452	BOLT M 8X 45 PLATED	1	1	1			
53	.	26366-080002	NUT M 8	2	2	2			
54	.	124160-11360	KNOB	2	2	2			
55	.	119260-11330	BONNET ASSY, (NON-ASB)	1	1	1			
56	..	124160-01751	CAP, LUB.OIL SUPPLY	1	1	1			
57	..	119260-03020	PLATE, SHELTER	1	1	1			
58	..	119260-03031	GASKET, (NON-ASB.)	1	1	1			(G)
61	..	119260-11310	GASKET, BONNET	1	1	1			(G)
62	..	119620-11390	JOINT	1	1	1			
63	..	22217-050000	SPRING WASHER 5	4	4	4			
64	..	24311-000320	O-RING 1A P-32.0	1	1	1			(G)
65	..	26557-050102	SCREW M 5X 10	4	4	4			
66	.	24311-000120	O-RING 1A P 12.0	2	2	2			(G)
67	.	129795-77800	PLUG, GLOW	3	3	3			
68	.	119620-77820	CONNECTOR, GLOW PLUG	1	1	1			
69	.	22351-060012	SPRING PIN 6X12	2	2	2			

REMARKS

I(1) REPAIR PART.

I(G) THESE PARTS ARE SOLD BY FIG.20,

I REF.NO.1.

5. SUCTION MANIFOLD & AIR CLEANER

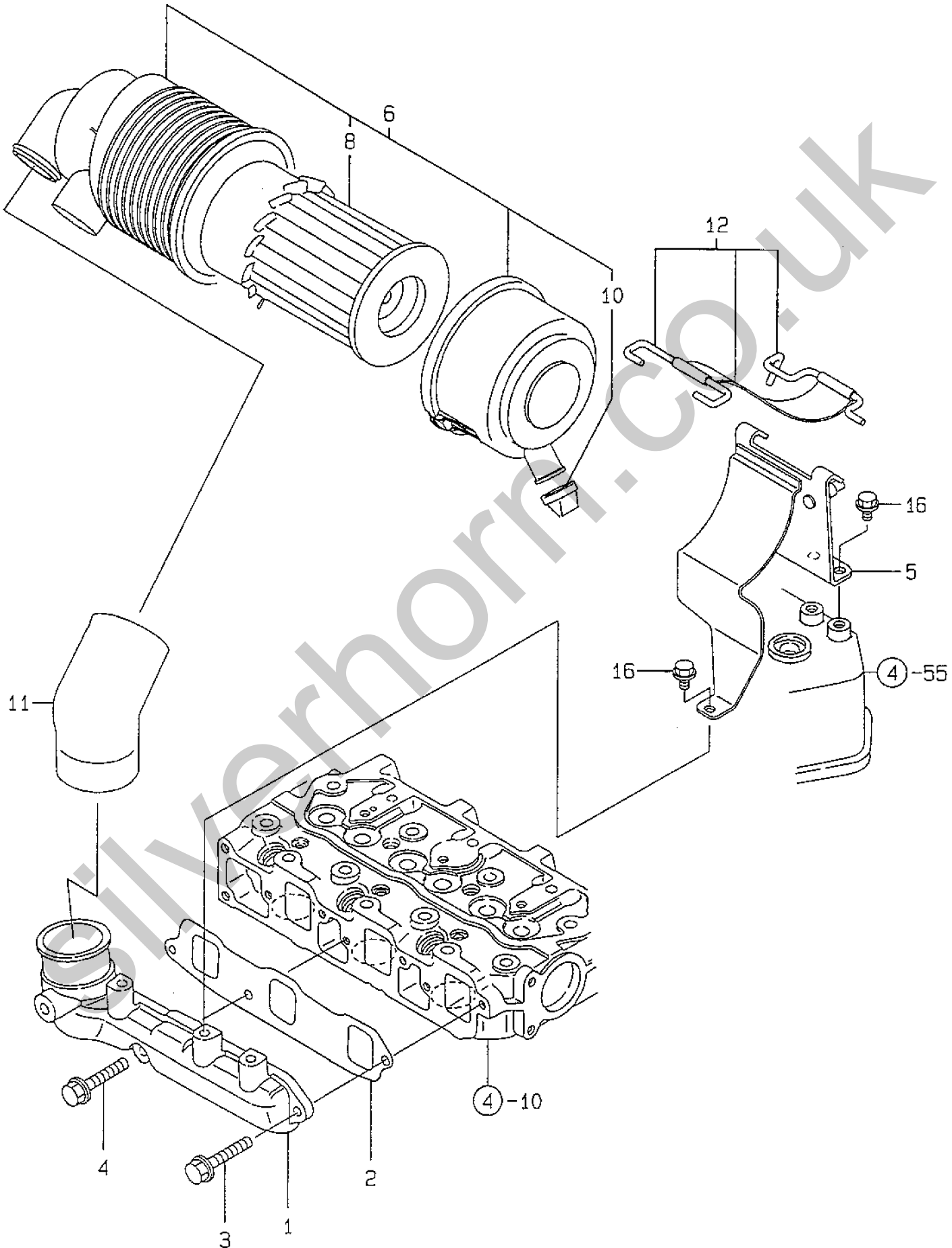

(5) SUCTION MANIFOLD & AIR CLEANER

(A)=3TNE68-SA (D)=

(B)=3TNE68-G1A (E)=

(C)=3TNE68-G2A (F)=

+-----+
 | 1B06 |
 | (1B01) |
 +-----+
 Y00R4510

REF. NO.	LEV. 0	PART NO.	DESCRIPTION	-----Q'TY-----						I P/U A R
				(A)	(B)	(C)	(D)	(E)	(F)	
1	.	119270-12100	MANIFOLD, SUCTION	1	1	1				
2	.	119270-12110	GASKET, SUC.MANIFOLD	1	1	1				(G)
3	.	26106-060162	BOLT M 6X 16 PLATED	2	2	2				
4	.	26106-060282	BOLT M 6X 28 PLATED	1	1	1				
5	.	119489-12600	SUPPORT, AIR CLEANER	1	1	1				
6	.	119653-12500	CLEANER ASSY, AIR	1	1	1				
8	..	119655-12560	ELEMENT	1	1	1				
10	..	119808-12540	VALVE, UNLOADER	1	1	1				
11	.	119462-12550	PIPE, SUCTION	1	1	1				
12	.	119865-12600	STAY	1	1	1				
16	.	26106-080122	BOLT M 8X 12 PLATED	3	3	3				

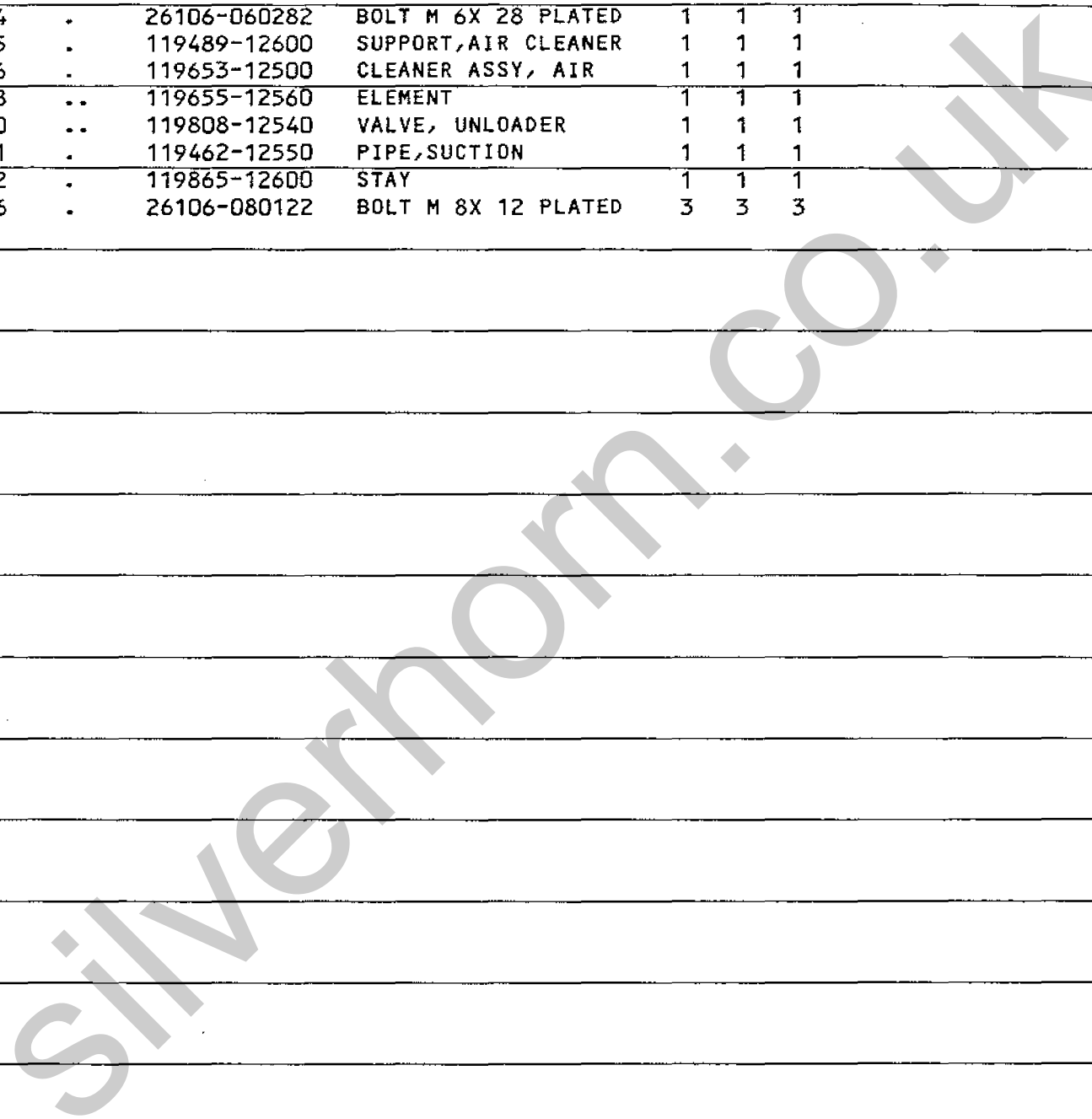

REMARKS

(G) THESE PARTS ARE SOLD BY FIG.20,
 I REF.NO-1.

6. EXHAUST MANIFOLD & SILENCER

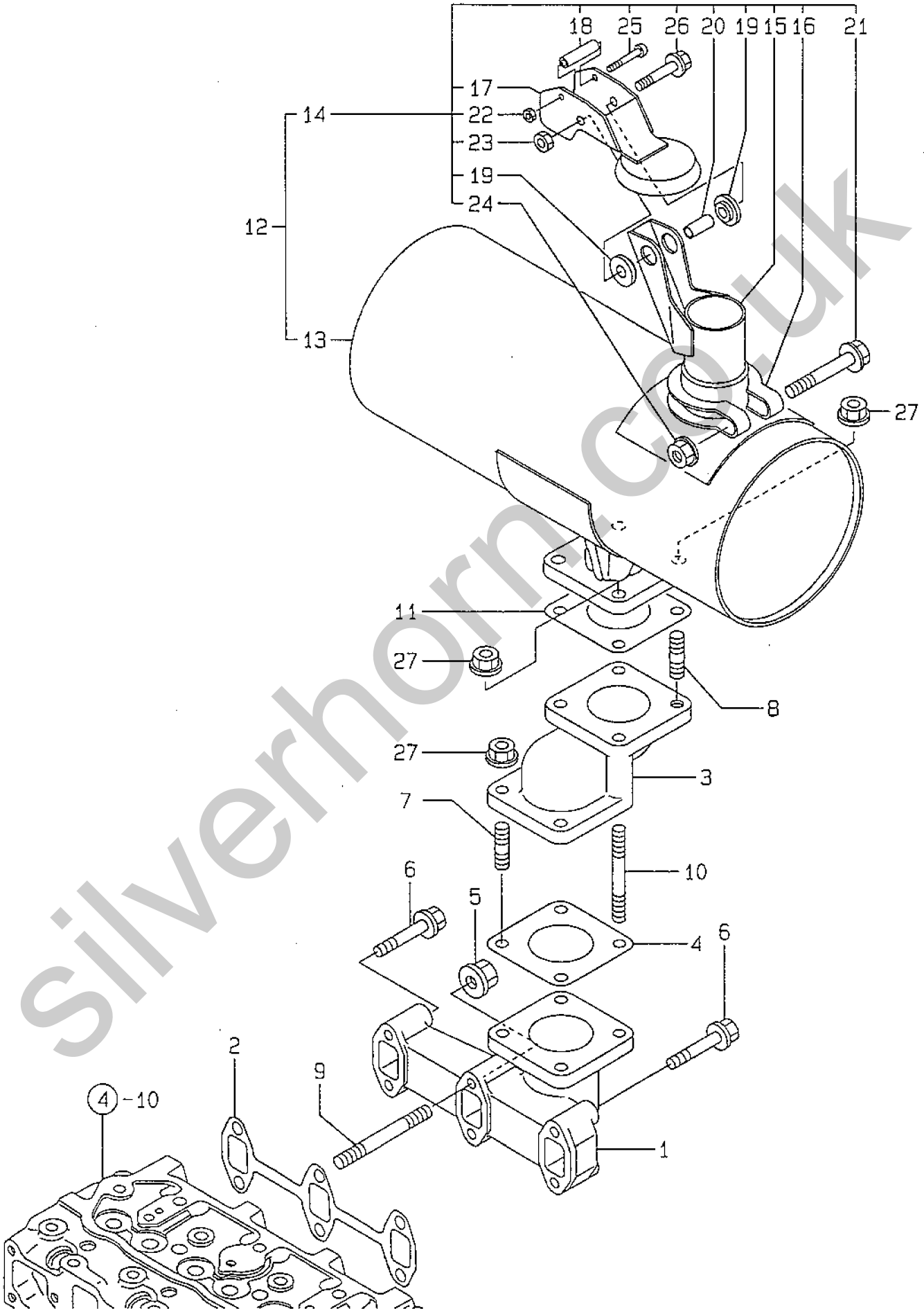

+-----+
 I 1B07 I
 I(1B01)I
 +-----+
 Y00R4510

(6) EXHAUST MANIFOLD & SILENCER

(A)=3TNE68-SA (D)=
 (B)=3TNE68-G1A (E)=
 (C)=3TNE68-G2A (F)=

REF. NO.	LEV. 0	PART NO.	DESCRIPTION	-----Q'TY-----						I	P/U	A	R
				(A)	(B)	(C)	(D)	(E)	(F)				
1	.	119253-13100	MANIFOLD, EXHAUST	1	1	1							
2	.	119260-13110	GASKET, EXH.MANIFOLD	1	1	1						(G)	
3	.	119840-13150	PIPE, EXHAUST	1	1	1							
4	.	121000-13201	GASKET, SILENCER	1	1	1						(G)	
5	.	194990-22050	NUT W/WASHER 8	2	2	2							
6	.	26106-080402	BOLT M 8X 40 PLATED	4	4	4							
7	.	26216-080222	STUD M 8X 22 PLATED	2	2	2							
8	.	26216-080222	STUD M 8X 22 PLATED	2	2	2							
9	.	26216-080402	STUD M 8X 40 PLATED	2	2	2							
10	.	26216-080702	STUD M 8X 70 PLATED	2	2	2							
11	.	121000-13201	GASKET, SILENCER	1	1	1						(G)	
12	.	119620-13501	SILENCER	1	1	1							
13	..	119620-13510	MUFFLER BODY ASSY	1	1	1							
14	..	119620-13520	TAILPIPE ASSY	1	1	1							
15	...	119620-13560	TAILPIPE	1	1	1							
16	...	124664-13580	CLAMP	1	1	1							
17	...	119358-13640	RAINCAP, MUFFLER	1	1	1							
18	...	121855-13821	SPACER(A)	1	1	1							
19	...	121855-13830	SPACER(B)	2	2	2							
20	...	123500-13840	SPACER(C)	1	1	1							
21	...	26106-080552	BOLT M 8X 55 PLATED	1	1	1							
22	...	26347-040002	U-NUT M 4	1	1	1							
23	...	26347-060002	U NUT 6	1	1	1							
24	...	26366-080002	NUT M 8	1	1	1							
25	...	26557-040352	SCREW M 4X 35	1	1	1							
26	...	26106-060402	BOLT M 6X 40 PLATED	1	1	1							
27	.	194990-22050	NUT W/WASHER 8	6	6	6							

REMARKS

1 (G) THESE PARTS ARE SOLD BY FIG.20,
 1 REF.NO.1.

Y100542

7. CAMSHAFT & DRIVING GEAR

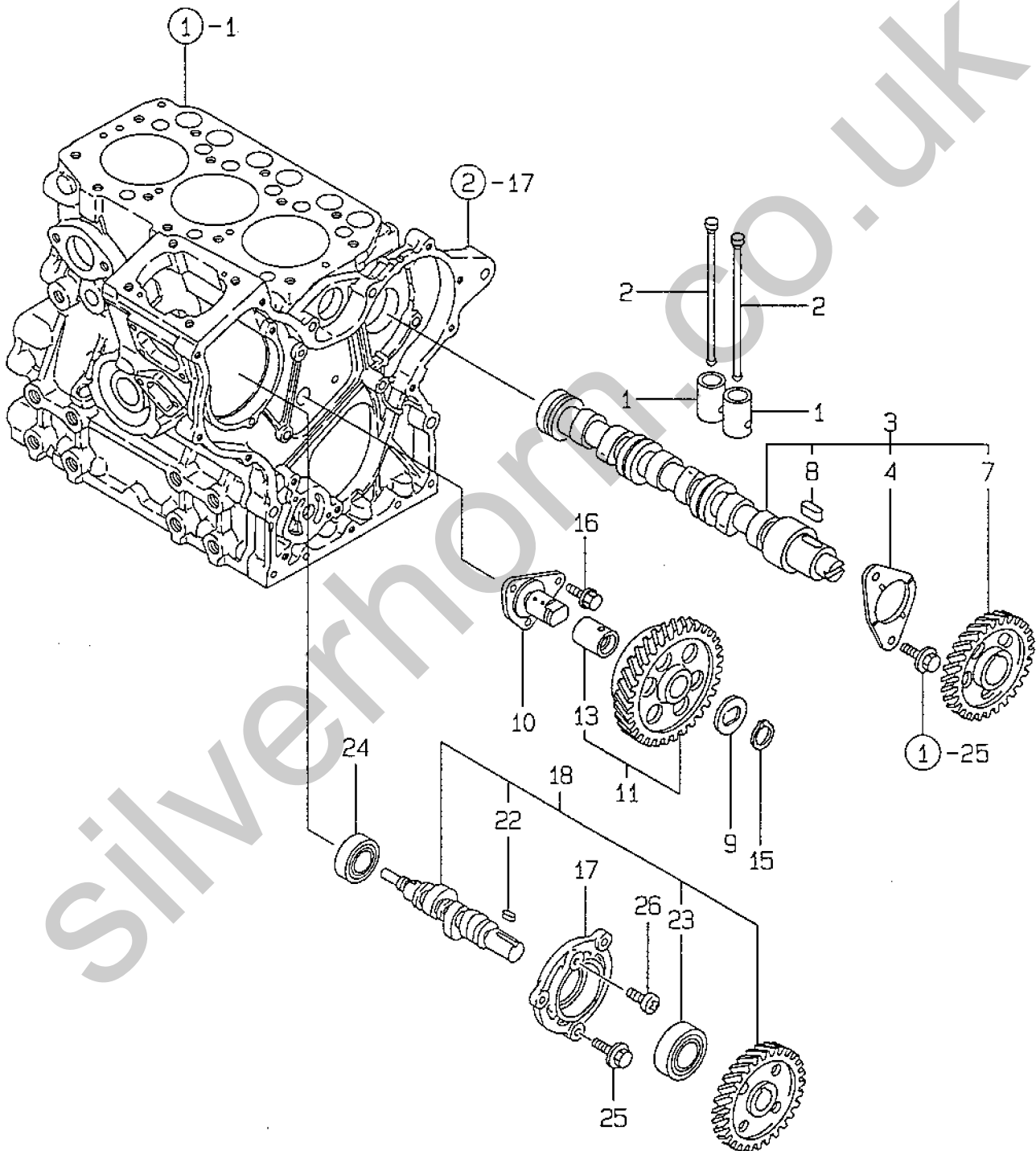

+-----+
 I 1B08 I
 I(1B01)I
 +-----+
 Y00R4510

(7) CAMSHAFT & DRIVING GEAR

(A)=3TNE68-SA (D)=
 (B)=3TNE68-G1A (E)=
 (C)=3TNE68-G2A (F)=

REF. NO.	LEV. 0	PART NO.	DESCRIPTION	-----Q'TY-----						I P/U A R
				(A)	(B)	(C)	(D)	(E)	(F)	
1	.	119260-14200	TAPPET	6	6	6				
2	.	119260-14400	ROD, PUSH	6	6	6				
3	.	119260-14580	CAMSHAFT ASSY	1	1	1				
4	..	119620-02450	BEARING, THRUST	1	1	1				
7	..	119260-14100	GEAR, CAMSHAFT	1	1	1				
8	..	22512-040120	KEY 4X 12	1	1	1				
9	.	119660-25022	RETAINER, IDLE GEAR	1	1	1				
10	.	119660-25052	SHAFT, IDLE GEAR	1	1	1				
11	.	119260-25100	GEAR W/BUSH, IDLE	1	1	1				
13	..	119620-25912	BUSH	1	1	1				(1)
15	.	22242-000200	CIRCLIP 20	1	1	1				
16	.	26106-060122	BOLT M 6X 12 PLATED	3	3	3				
17	.	119660-01821	BEARING, FUEL CAM.	1	1	1				
18	.	119225-14200	CAM ASSY, F.I. PUMP	1	1	1				
22	..	22512-040120	KEY 4X 12	1	1	1				
*23	..	24102-063034	BALL BEARING 6303U	1	1	1				
*24	.	24101-062034	BALL BEARING	1	1	1				
25	.	26106-060162	BOLT M 6X 16 PLATED	3	3	3				
26	.	26587-080102	SCREW M 8X 10	1	1	1				

REMARKS

(1) REPAIR PART.

Y100543

8. CRANKSHAFT & PISTON

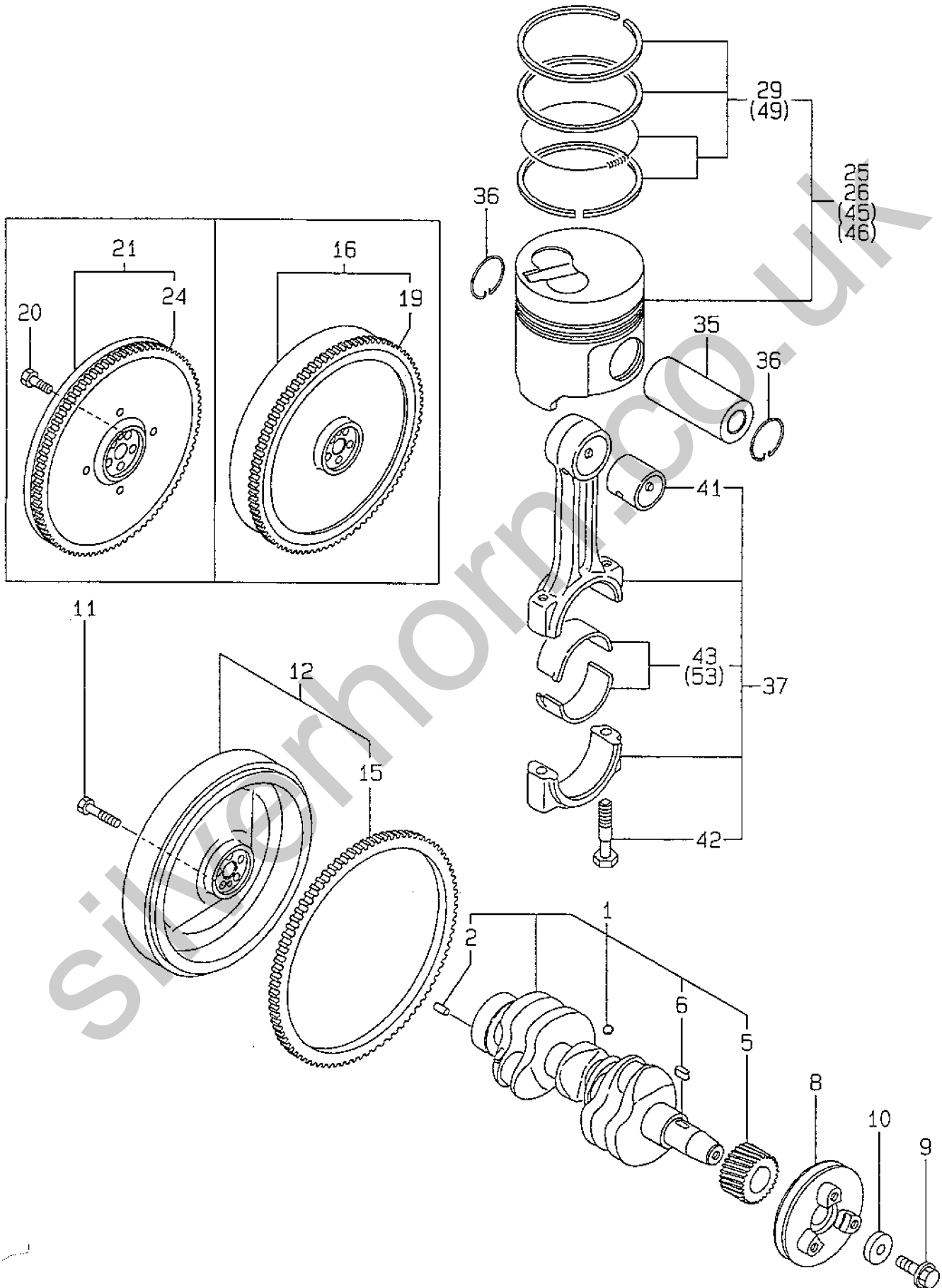

(8) CRANKSHAFT & PISTON

(A)=3TNE68-SA (D)=
 (B)=3TNE68-G1A (E)=
 (C)=3TNE68-G2A (F)=

1 1809 I
 I(1801)I
 +-----+
 Y00R4510

REF. NO.	LEV. 0	PART NO.	DESCRIPTION	-----Q'TY-----						I P/U A R
				(A)	(B)	(C)	(D)	(E)	(F)	
1	.	119265-21700	CRANKSHAFT ASSY	1	1	1				
2	..	129100-01580	PARALLEL PIN 8X16	1	1	1				
5	..	119260-21200	GEAR, CRANKSHAFT	1	1	1				
6	..	22512-040120	KEY 4X 12	1	1	1				
8	.	119260-21650	V-PULLEY	1	1	1				
9	.	119621-21680	BOLT M12X1.25, FLANGE	1	1	1				
10	.	119620-21941	WASHER	1	1	1				
11	.	121111-21501	BOLT, FLYWHEEL	5	5	5				(1)
12	.	119688-21590	FLYWHEEL CMP	1	1	1				(2)
15	..	119865-21600	GEAR, RING	1	1	1				
16	.	119600-21580	FLYWHEEL ASSY	1		1				(3)
19	..	119865-21600	GEAR, RING	1		1				
20	.	119620-21500	BOLT, FLYWHEEL	5		5				(4)
21	.	119620-21591	FLYWHEEL W/RING GEAR	1		1				(4)
24	..	124060-21600	GEAR, RING	1		1				
25	.	119265-22601	PISTON W/RINGS	3	3					
26	.	119265-22090	PISTON W/RINGS			3				
29	..	119265-22500	RING SET	3	3	3				
35	.	119265-22300	PIN, PISTON	3	3	3				
36	.	22252-000200	CIRCLIP 20	6	6	6				
37	.	119265-23100	ROD ASSY, CONNECTING	3	3	3				
41	..	119260-23910	BUSH, PISTON PIN	3	3	3				(5)
42	..	119265-23200	BOLT, ROD	6	6	6				
43	..	719260-23600	BEARING, CRANKPIN	3	3	3				
45	.	119265-22930	PISTON W/RING O.S=.25	3	3					(6)
46	.	119265-22900	PISTON ASSY O.S=0.25			3				(6)
49	..	119265-22950	RING SET O.S=0.25	3	3	3				(6)
53	.	719260-23610	BEARING, PIN U.S=0.25	3	3	3				(7)

REMARKS

- (1) SAE CLUTCH(FOR STD)/SAE GENE/
 I SEMI SAE#5 FOR -SA, SAE GENE(FOR
 I STD)FOR -G1A,SAE GENE(FOR STD)/
 I SEMI SAE#5 FOR -G2A.
 (2) SAE CLUTCH(FOR STD)/SAE GENE FOR
 I -SA,SAE GENE(FOR STD)FOR -G1A,G2A
 (3) FOR SEMI SAE#5.
 (4) FOR BACK PLATE.
 (5) REPAIR PART.
 (6) OVER-SIZE(O.S=0.25)PART.
 (7) UNDER-SIZE(U.S=0.25)PART.

9.LUB.OIL SYSTEM

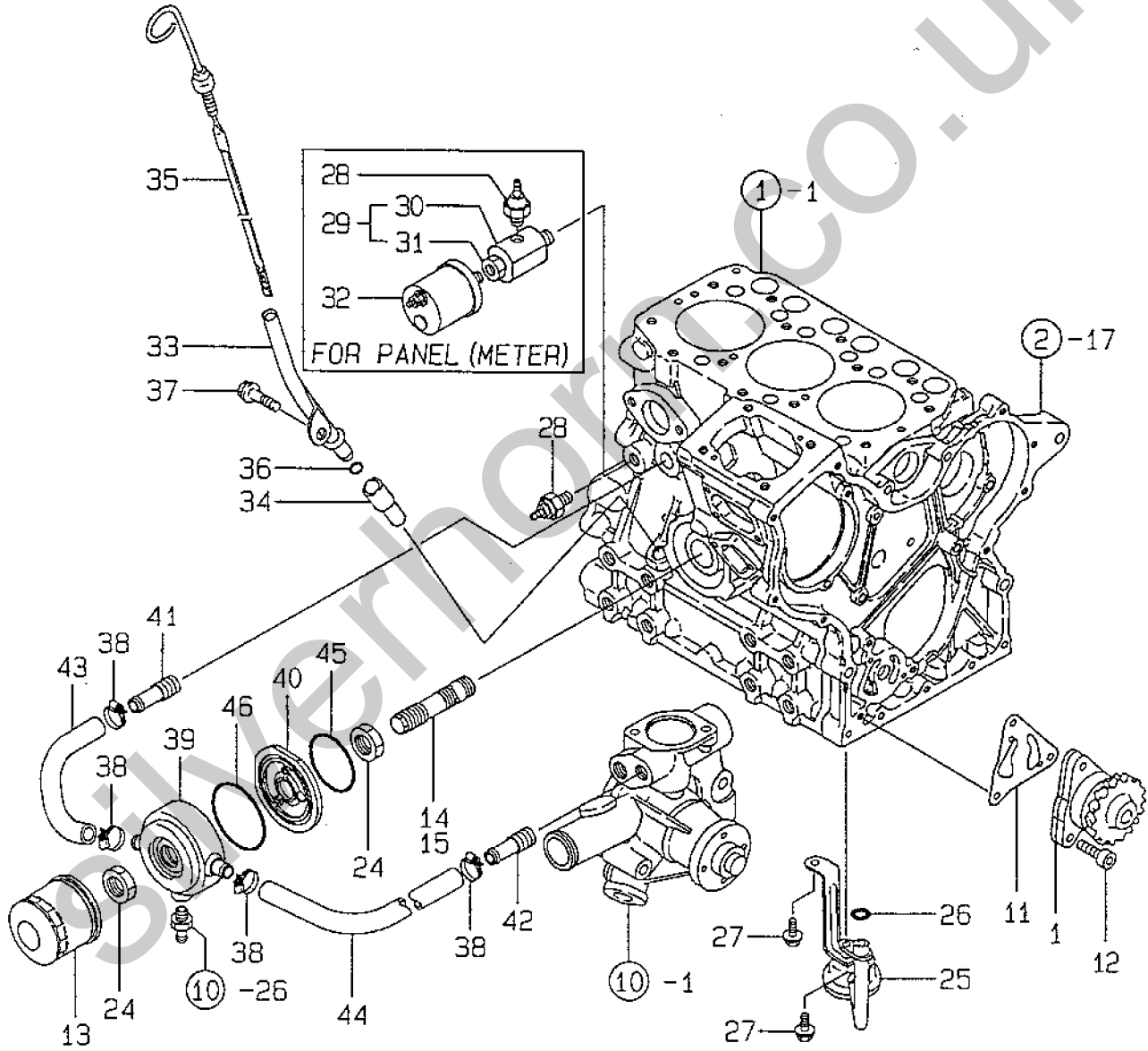

(9) LUB.OIL SYSTEM

+-----+
 I 1B10 I
 I(1B01)I
 +-----+
 Y0DR4510

(A)=3TNE68-SA (D)=
 (B)=3TNE68-G1A (E)=
 (C)=3TNE68-G2A (F)=

REF. NO.	LEV. 0	PART NO.	DESCRIPTION	-----Q'TY-----						I P/U A R
				(A)	(B)	(C)	(D)	(E)	(F)	
1	.	119260-32000	PUMP ASSY, LUB. OIL	1	1	1				
11	.	119660-32020	GASKET, L.O.PUMP	1	1	1				(G)
12	.	26450-060202	BOLT M 6X 20	3	3	3				
13	.	119305-35150	FILTER, LUB. OIL	1	1	1				
14	.	119225-35300	VALVE ASSY,OIL PRESS	1	1					
15	.	119265-35300	VALVE ASSY,OIL PRESS			1				
24	.	129150-35350	NUT	1	1	2				
25	.	119260-35081	PIPE ASSY,OIL INTAKE	1	1	1				
26	.	24311-000120	O-RING 1A P 12.0	1	1	1				(G)
27	.	26106-060122	BOLT M 6X 12 PLATED	2	2	2				
28	.	124160-39450	SWITCH, OIL PRESSURE	1	1	1				
29	.	171375-39600	DAMPER ASSY	1	1	1				(1)
30	..	129470-39610	DAMPER	1	1	1				(1)
31	..	23161-020100	BUSH PT1/4X1/8	1	1	1				(1)
32	.	144626-91560	TACHO UNIT	1	1	1				(1)
33	.	119225-34810	GUIDE, DIPSTICK	1	1	1				
34	.	119260-34810	GUIDE, DIPSTICK	1	1	1				
35	.	119620-34822	DIPSTICK, LUB. OIL	1	1	1				
36	.	24311-240100	O-RING 1A P-10A	1	1	1				
37	.	26106-060102	BOLT M 6X 10 PLATED	1	1	1				
38	.	171008-03990	CLAMP 25			4				
39	.	119642-33030	COOLER, OIL			1				
40	.	119642-33100	BRACKET			1				
41	.	129122-44480	JOINT			1				
42	.	129122-44480	JOINT			1				
43	.	119642-49030	PIPE			1				
44	.	129403-49050	PIPE,COOLER-C.W.PUMP			1				
45	.	24321-000600	O-RING 1A G-60.0			1				(G)
46	.	24321-000700	O-RING 1A G-70.0			1				(G)

----- REMARKS -----
 I (1) FOR PANEL (METER).
 I (G) THESE PARTS ARE SOLD BY FIG.20,
 I REF.NO.1.

10. COOLING WATER SYSTEM

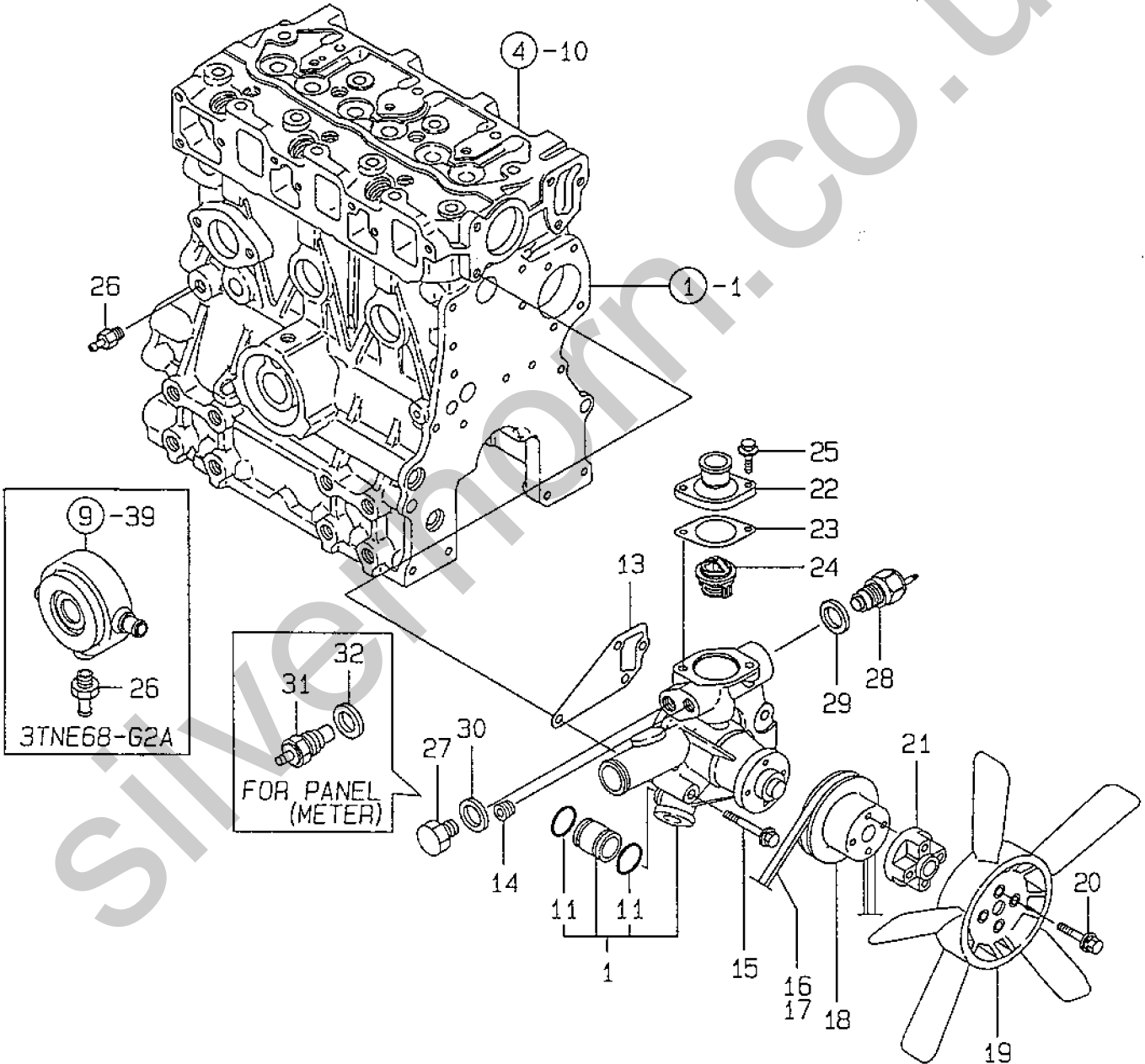

(10) COOLING WATER SYSTEM

(A)=3TNE68-SA (D)=

(B)=3TNE68-G1A (E)=

(C)=3TNE68-G2A (F)=

REF. NO.	LEV. 0	PART NO.	DESCRIPTION	-----Q'TY-----						I P/U A R
				(A)	(B)	(C)	(D)	(E)	(F)	
1	.	119265-42002	PUMP ASSY, C. WATER	1	1	1				
11	..	24311-000210	O-RING 1A P-21.0	2	2	2				
13	.	119260-42020	GASKET, C.W. PUMP	1	1	1				(G)
14	.	171056-49120	PLUG, DRAIN	1	1					
15	.	26106-080452	BOLT M 8X 45 PLATED	3	3	3				
16	.	104514-42780	V-BELT (HM-33)	1	1					
17	.	119256-42290	V-BELT 33.5							1
18	.	119620-42350	V-PULLEY, C.W. PUMP	1	1	1				
19	.	124700-44740	FAN, COOLING	1	1	1				
20	.	26014-060352	BOLT M 6X 35	4	4	4				
21	.	121267-44760	SPACER	1	1	1				
22	.	129350-49530	COVER, THERMOSTAT	1	1	1				
23	.	129350-49541	GASKET, (NON-ASB.)	1	1	1				(G)
24	.	129350-49800	THERMOSTAT (71°C	1	1	1				
25	.	26106-080202	BOLT M 8X 20 PLATED	2	2	2				
26	.	121550-49111	JOINT PT1/4	1	1	1				
27	.	121450-42450	PLUG M16	1	1	1				
28	.	121250-44901	SWITCH, THERMO(110°C	1	1	1				
29	.	124465-44950	GASKET 16	1	1	1				(G)
30	.	124465-44950	GASKET 16	1	1	1				(G)
31	.	124250-49351	THERMOMETER	1	1	1				(1)
32	.	129150-49360	GASKET 10	1	1	1				(1)

REMARKS

(1) FOR PANEL(METER).

(G) THESE PARTS ARE SOLD BY FIG.20,

REF.NO.1.

11. RADIATOR

REFER TO Fig.3

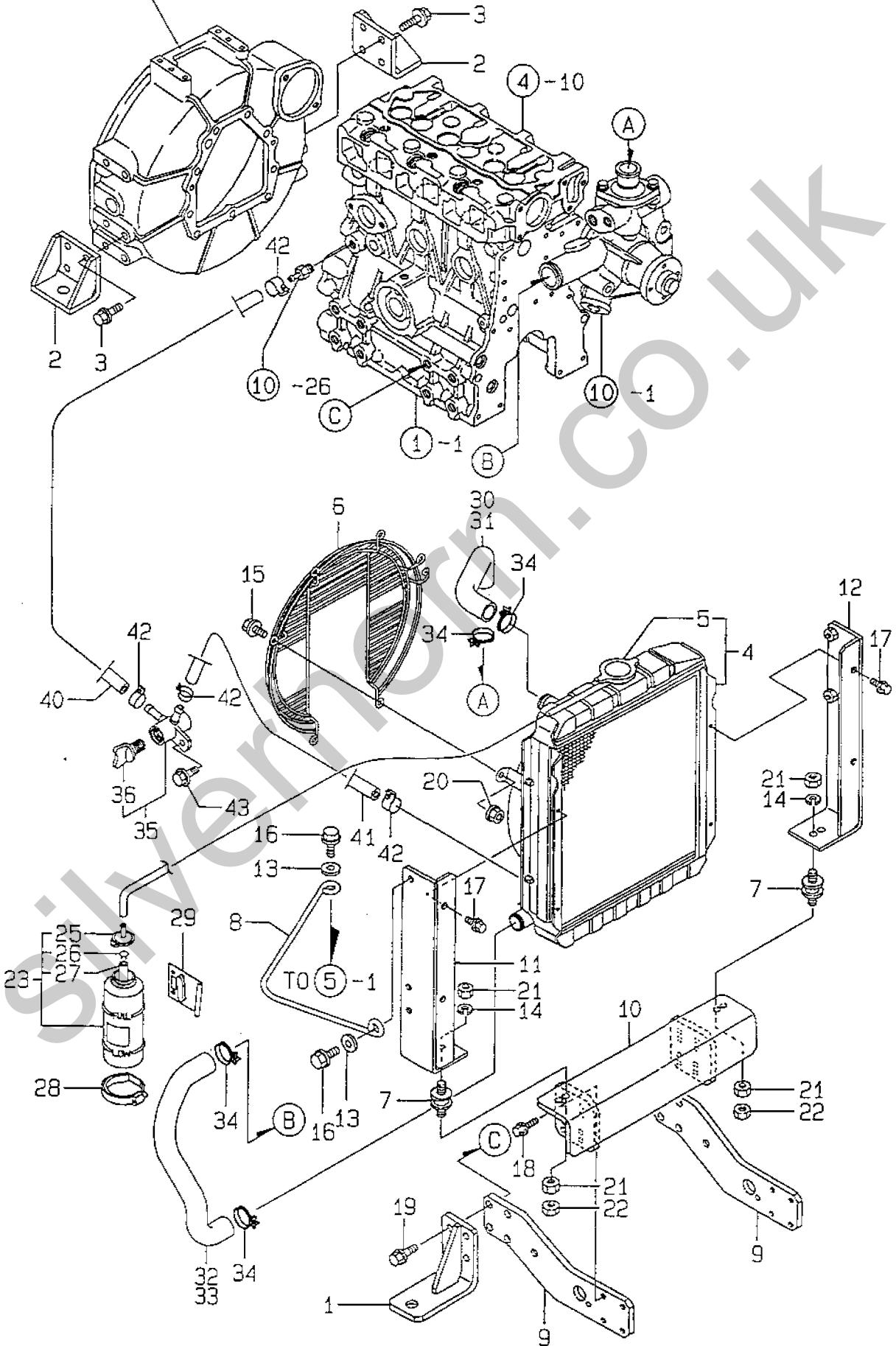

(11) RADIATOR

(A)=3TNE68-SA (D)=
 (B)=3TNE68-G1A (E)=
 (C)=3TNE68-G2A (F)=

+-----+
 | 1B12 |
 | (1B01) |
 +-----+
 Y00R4510

REF. NO.	LEV. 0	PART NO.	DESCRIPTION	-----Q'ITY-----						I P/U A R
				(A)	(B)	(C)	(D)	(E)	(F)	
1	.	119288-08100	BRACKET (A), ENGINE	2	2					
2	.	119888-08110	BRACKET (B), ENGINE	2	2					
3	.	26106-100202	BOLT M10X 20 PLATED	8	8					
4	.	119621-44500	RADIATOR	1	1	1				
5	..	119259-44570	CAP, RADIATOR	1	1	1				
6	.	119621-44560	FAN-GUARD	1	1	1				
7	.	121400-44650	ABSORBER, SHOCK	2	2					
8	.	119265-44940	RETAINING BAR	1	1					
9	.	119688-44950	BRACKET (A)	2	2					
10	.	119688-44961	BRACKET (B), RADIATOR	1	1					
11	.	119688-44971	BRACKET (L)	1	1					
12	.	119688-44981	BRACKET (R)	1	1					
13	.	22137-080000	WASHER 8, POLISHED	2	2					
14	.	22217-100000	SPRING WASHER 10	2	2					
15	.	26106-080122	BOLT M 8X 12 PLATED	6	6	6				
16	.	26106-080162	BOLT M 8X 16 PLATED	2	2					
17	.	26106-080202	BOLT M 8X 20 PLATED	4	4					
18	.	26106-080252	BOLT M 8X 25 PLATED	8	8					
19	.	26116-100302	BOLT M10X 30 PLATED	8	8					
20	.	26366-080002	NUT M 8	6	6	6				
21	.	26716-100002	NUT M10	4	4					
22	.	26756-100002	LOCK NUT M10 PLATED	2	2					
23	.	124450-44510	TANK	1	1	1				
25	..	124450-44530	CAP	1	1	1				
26	..	124450-44560	CLAMP	1	1	1				
27	..	23061-070230	PIPE 7X 230	1	1	1				
28	.	124450-44550	CLAMP, SUB-TANK	1	1	1				
29	.	121256-44600	BRACKET, SUB-TANK	1	1	1				
30	.	119688-49010	PIPE (A), C. WATER	1	1	1				(1)
31	.	119288-49010	PIPE A, COOLING WATER	1	1					
32	.	119645-49020	PIPE (B), C. WATER	1	1	1				(1)
33	.	119280-49020	PIPE (B), C. WATER	1	1					
34	.	23010-038000	CLAMP 38	4	4	4				
35	.	129150-49100	COCK ASSY, 3-WAY	1	1	1				
36	..	129150-49080	COCK, DRAIN	1	1	1				
40	.	121750-49150	PIPE, C. WATER	1	1					
41	.	121023-49150	HOSE, WATER DRAIN 165	1	1					
42	.	124766-59050	CLAMP 12	4	4					
43	.	26106-080162	BOLT M 8X 16 PLATED	1	1					

REMARKS

(1) SET PART.

Y100547

12. FUEL INJECTION PUMP

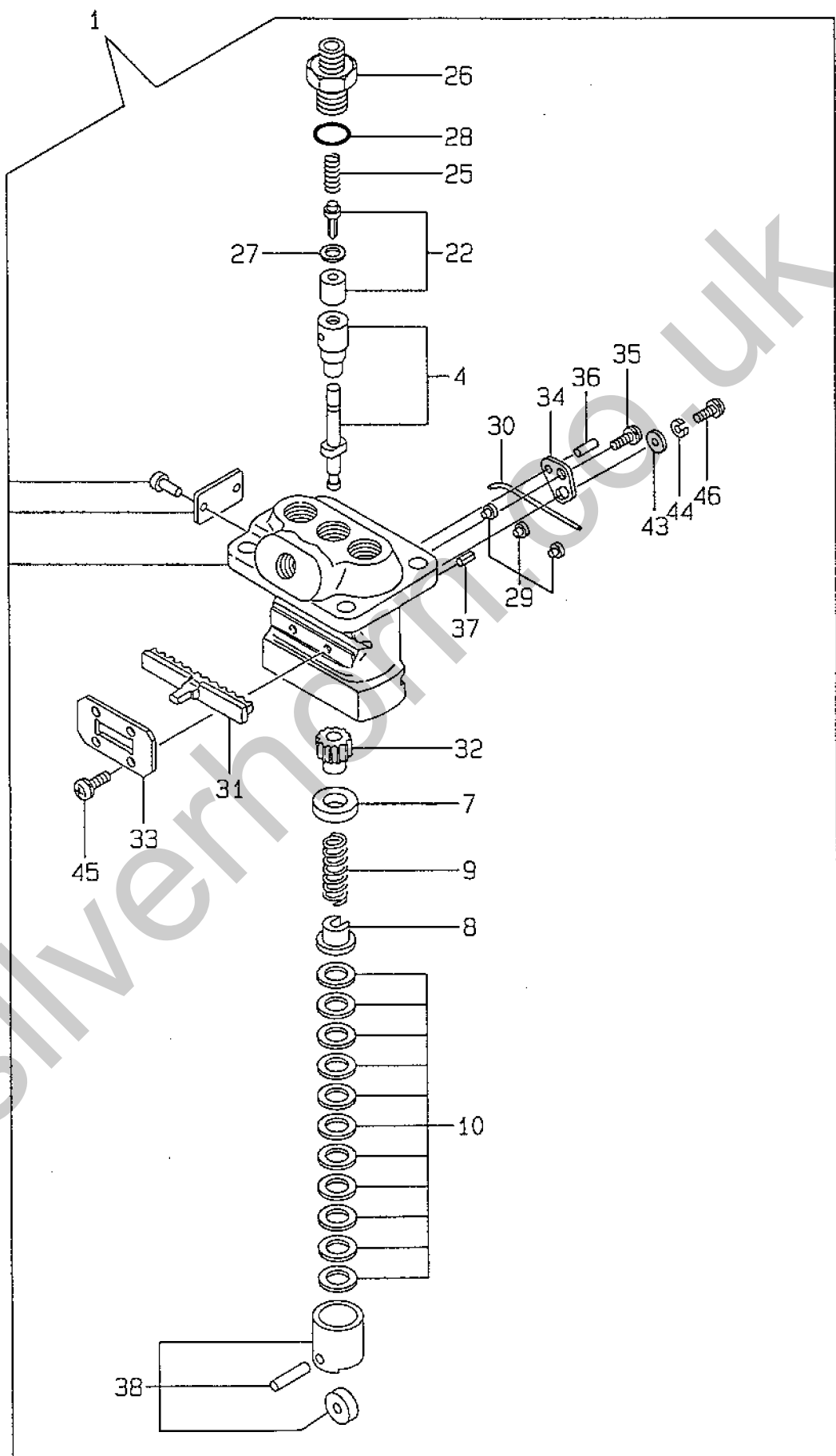

+-----+
 I 1B13 I
 I (1B01) I
 +-----+
 Y00R4510

(12) FUEL INJECTION PUMP

(A)=3TNE68-SA (D)=

(B)=3TNE68-G1A (E)=

(C)=3TNE68-G2A (F)=

REF. NO.	LEV. 0	PART NO.	DESCRIPTION	-----Q'TY----- I P/U A R					
				(A)	(B)	(C)	(D)	(E)	(F)
1	.	719225-51100	F.I.PUMP ASSY	1	1	1			
4	..	119225-51100	PLUNGER W/BARREL	3	3	3			
7	..	119620-51170	RETAINER	3	3	3			
8	..	119620-51180	RETAINER	3	3	3			
9	..	119620-51190	SPRING, PLUNGER	3	3	3			
10	..	119620-51250	SHIM PACK	3	3	3			
22	..	119225-51300	VALVE W/SEAT, DELIV.	3	3	3			
25	..	105546-51330	SPRING, DELIV. VALVE	3	3	3			
26	..	119620-51340	HOLDER, DELIV. VALVE	3	3	3			
27	..	119620-51350	GASKET, DELIVERY	3	3	3			
28	..	119620-51370	O-RING	3	3	3			
29	..	119620-51450	GUIDE, PLUNGER	3	3	3			
30	..	119620-51461	PIN	1	1	1			
31	..	119660-51500	RACK	1	1	1			
32	..	119620-51510	PINION	3	3	3			
33	..	119660-51530	RETAINER, RACK	1	1	1			
34	..	119620-51650	PLATE	2	2	2			
35	..	119620-51660	SCREW	2	2	2			
36	..	119620-51670	PIN	2	2	2			
37	..	119620-51680	PIN	1	1	1			
38	..	119620-51700	TAPPET ASSY	3	3	3			
43	..	22137-040000	WASHER 4, POLISHED	2	2	2			
44	..	22217-040000	SPRING WASHER 4	2	2	2			
45	..	26022-040082	SCREW M 4X 8	4	4	4			
46	..	26587-040102	SCREW M 4X 10	2	2	2			

13. GOVERNOR

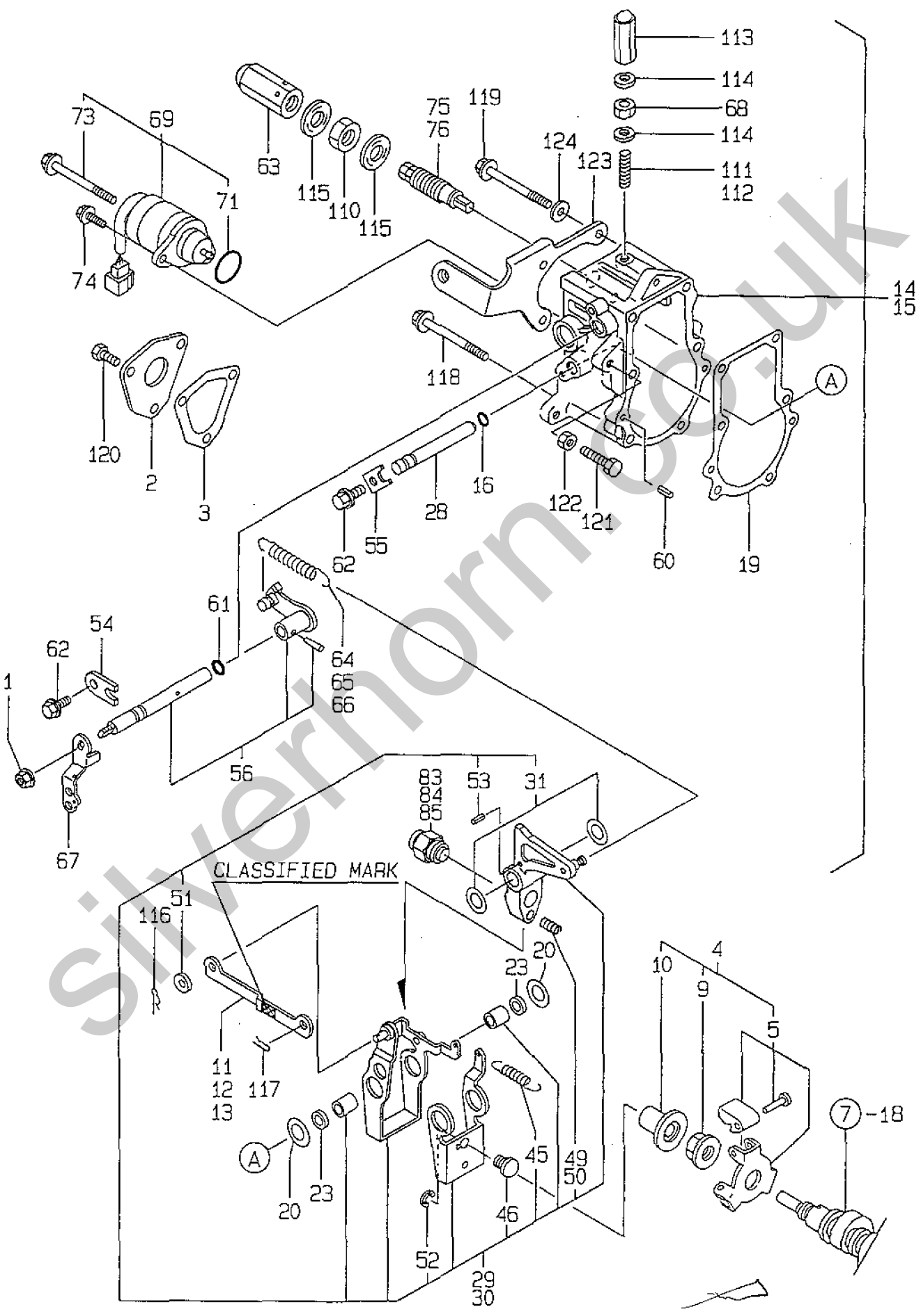

(13) GOVERNOR

 +-----+
 I 1B14 I
 I (1B01) I
 +-----+
 Y00R4510

 (A)=3TNE68-SA (D)=
 (B)=3TNE68-G1A (E)=
 (C)=3TNE68-G2A (F)=

REF. NO.	LEV. 0	PART NO.	DESCRIPTION	-----Q'TY----- I P/U A R					
				(A)	(B)	(C)	(D)	(E)	(F)
1	.	194990-22050	NUT W/WASHER 8	1	1	1			
2	.	119660-61060	COVER, GOVERNOR CASE	1	1	1			
3	.	119660-61071	GASKET, (NON-ASB.)	1	1	1			
4	.	119600-61100	DRIVING SET, GOV.	1	1	1			
5	..	119600-61200	WEIGHT ASSY, GOV.	1	1	1			
9	..	119660-61300	NUT, GOVERNOR WEIGHT	1	1	1			
10	..	119660-61341	SLEEVE, GOVERNOR	1	1	1			
11	.	119660-61121	LINK L=88.8(NO COLOR	1	1	1			(1)
12	.	119660-61140	LINK L=88.6(WHITE)	1	1	1			(1)
13	.	119660-61150	LINK L=89.0(RED)	1	1	1			(1)
14	.	119632-61200	CASE ASSY, GOVERNOR	1	1				
15	.	119288-61200	CASE ASSY, GOVERNOR			1			
16	..	129155-51280	O-RING S6	1	1	1			
19	..	119660-61052	GASKET, (NON-ASB.)	1	1	1			
20	..	119660-61460	SHIM SET	1	1	1			
23	..	129155-61480	SPACER ASSY	2	2	2			
28	..	119660-61491	SHAFT, GOVERNOR LEVER	1	1	1			
29	..	119232-61510	LEVER ASSY, GOVERNOR	1	1				
30	..	119288-61510	LEVER ASSY, GOVERNOR			1			
31	...	174307-51700	SHIM SET	2	2	2			
45	...	119232-61540	SPRING, LEVER	1	1	1			
46	...	119600-61541	SHIFTER, P.T.O.	1	1	1			
49	...	119660-61651	SPRING, STARTING	1	1				
50	...	119600-61650	SPRING, STARTING			1			
51	...	22117-040000	WASHER 4	1	1	1			
52	...	22272-000040	CIRCLIP E- 4	1	1	1			
53	...	22351-030014	SPRING PIN 3X14	1	1	1			
54	..	119600-61900	RETAINER, SHAFT	1	1	1			
55	..	119660-61901	RETAINER, SHAFT	1	1	1			
56	..	119285-66080	SHAFT ASSY, REGULATOR	1	1	1			
60	..	22351-040010	SPRING PIN 4X10	2	2	2			
61	..	24341-000070	O-RING 1A S-7.0	1	1	1			
62	..	26106-060102	BOLT M 6X 10 PLATED	2	2	2			
63	.	129100-61930	NUT, CAP	1	1	1			
64	.	119600-66020	SPRING, REGULATOR	1					
65	.	119489-66010	SPRING, REGULATOR		1				
66	.	119260-66010	SPRING, REGULATOR			1			
67	.	119621-66051	LEVER, REGULATOR	1	1	1			
68	.	124550-66370	LOCK NUT M 6	1	1	1			
69	.	119653-66500	ENGINE STOP DEVICE	1	1	1			
71	..	24341-000280	O-RING 1A S-28.0	1	1	1			
73	..	26106-060952	BOLT M 6X 95 PLATED	1	1	1			
74	.	121465-59950	BOLT M 6X 16, PLATED	1	1	1			
75	.	119600-66530	TORQUE SPRING ASSY	1					
76	.	119629-66510	TORQUE SPRING ASSY		1	1			
83	.	119654-66700	ANGLEIGH ASSY	1					
84	.	119610-66700	ANGLEICH ASSY		1				
85	.	119260-66720	ANGLEICH ASSY			1			
110	.	26776-120002	LOCK NUT M12 PLATED	1	1	1			
111	.	121575-66830	SCREW, ADJUST	1		1			
112	.	171002-66830	SCREW, ADJUST		1				
113	.	119600-66840	NUT, CAP	1	1	1			
114	.	22190-060003	WAHER 6, SEAL	2	2	2			
115	.	22190-120002	SEAL WASHER 12S	2	2	2			

** CONTINUE **

Y100549

13. GOVERNOR

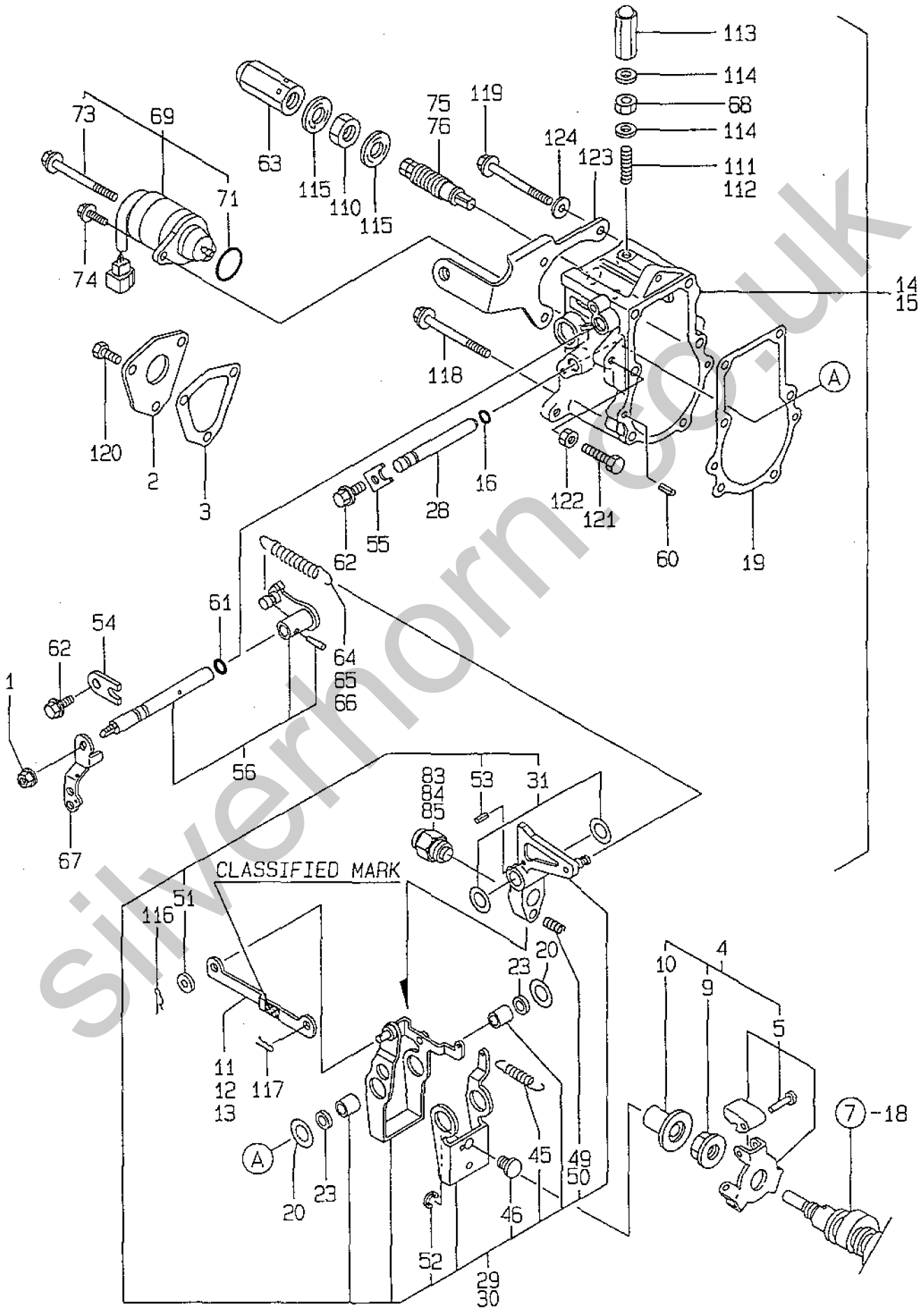

+-----+
 I 1815 I
 I(1801)I
 +-----+
 Y00R4510

(A)=3TNE68-SA (D)=
 (B)=3TNE68-G1A (E)=
 (C)=3TNE68-G2A (F)=

REF. NO.	LEV. 0	PART NO.	DESCRIPTION	-----Q'ITY----- I P/U A R					
				(A)	(B)	(C)	(D)	(E)	(F)
116	.	22360-040000	SNAP PIN 4	1	1	1			
117	.	22360-060000	SNAP PIN 6	1	1	1			
118	.	26106-060702	BOLT M 6X 70 PLATED	2	2	2			
119	.	26106-060752	BOLT M 6X 75 PLATED	3	3	3			
120	.	26116-050102	BOLT M 5X 10 PLATED	3	3	3			
121	.	26116-060304	BOLT M 6X 30 PLATED	1	1	1			
122	.	26756-060002	LOCK NUT M 6 PLATED	1	1	1			
123	.	119288-55900	BRACKET, FUEL FILTER	1	1	1			
124	.	22111-060000		3	3	3			

----- REMARKS -----

(1) SELECTIVE PARTS : CERTAIN THE
 CLASSIFICATION MARK, THEN PLACE
 YOUR ORDER.(REF. TO ILLUSTRATION)

14. FUEL INJECTION VALVE

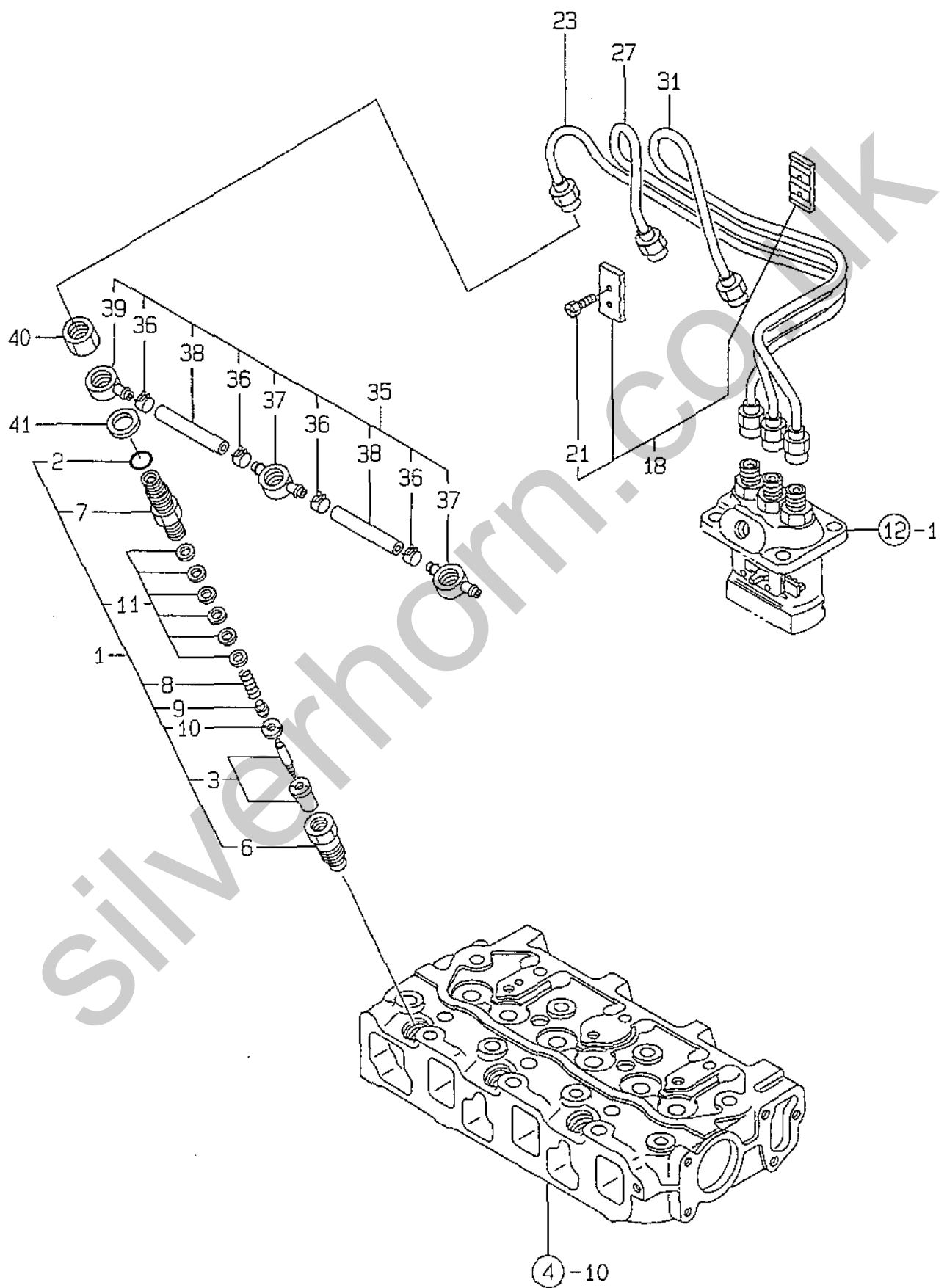

(14) FUEL INJECTION VALVE

(A)=3TNE68-SA (D)=
 (B)=3TNE68-G1A (E)=
 (C)=3TNE68-G2A (F)=

+-----+
 | 1B16 |
 | (1B01) |
 +-----+
 Y0DR4510

REF. NO.	LEV. 0	PART NO.	DESCRIPTION	-----Q'TY----- I P/U A R					
				(A)	(B)	(C)	(D)	(E)	(F)
1	.	719620-53700	VALVE ASSY, F.INJECT	3	3	3			
2	..	129155-51580	O-RING	3	3	3			(G)
3	..	119620-53000	NOZZLE ASSY, F.INJECT	3	3	3			
6	..	119620-53080	NUT, VALVE W/CASE	3	3	3			
7	..	119620-53100	HOLDER, VALVE W/CASE	3	3	3			
8	..	119620-53120	SPRING, VALVE	3	3	3			
9	..	114250-53130	SEAT, NOZZLE SPRING	3	3	3			
10	..	119620-53140	SPACER, VALVE STOP	3	3	3			
11	..	114250-53400	SHIM PACK	3	3	3			
18	.	129150-59120	RETAINER, INJ. PIPE	1	1	1			
21	..	129150-59131	BOLT M4X14, HEX.SCKT.	2	2	2			
23	.	119225-59810	PIPE (1), FUEL INJECT	1	1	1			
27	.	119260-59820	PIPE (2), FUEL INJECT	1	1	1			
31	.	119260-59830	PIPE (3), FUEL INJECT	1	1	1			
35	.	119260-59540	PIPE ASSY, FUEL OVER	1	1	1			
36	..	124066-59100	CLAMP 8	4	4	4			
37	..	119260-59530	JOINT (A)	2	2	2			
38	..	119260-59550	PIPE, FUEL	2	2	2			
39	..	119260-59520	JOINT (B)	1	1	1			
40	.	119620-59700	NUT	3	3	3			
41	.	23414-140000	GASKET 14, ROUND	3	3	3			(G)

----- REMARKS -----

(G) THESE PARTS ARE SOLD BY FIG.20,
 I REF.NO.1.

15. FUEL FILTER

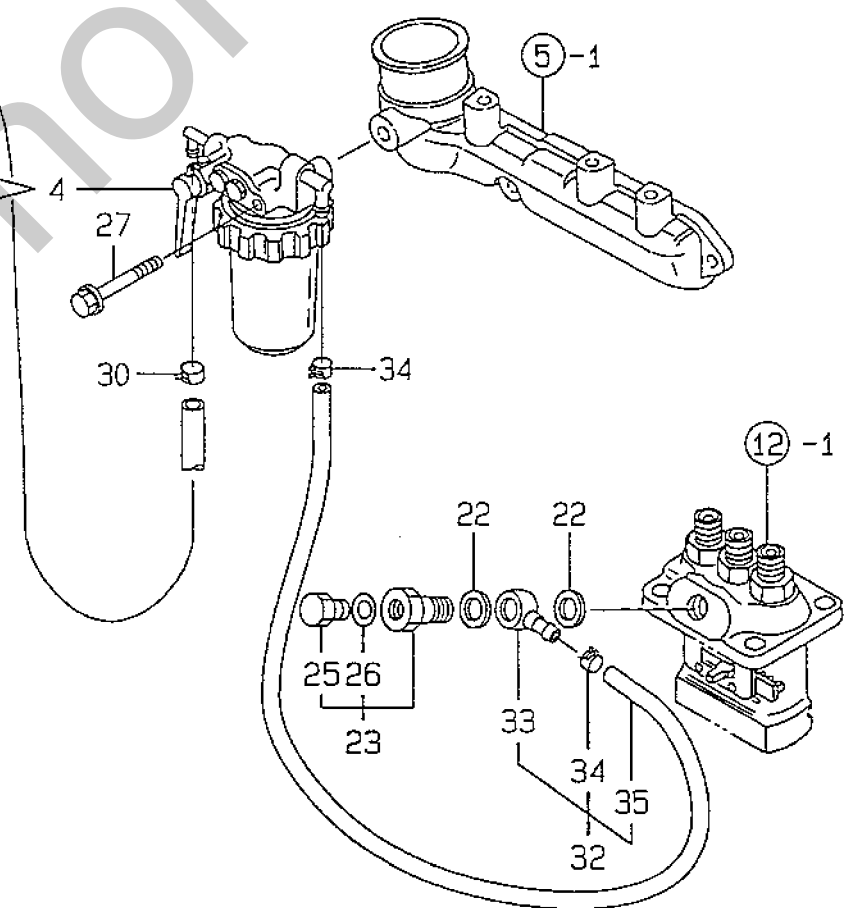
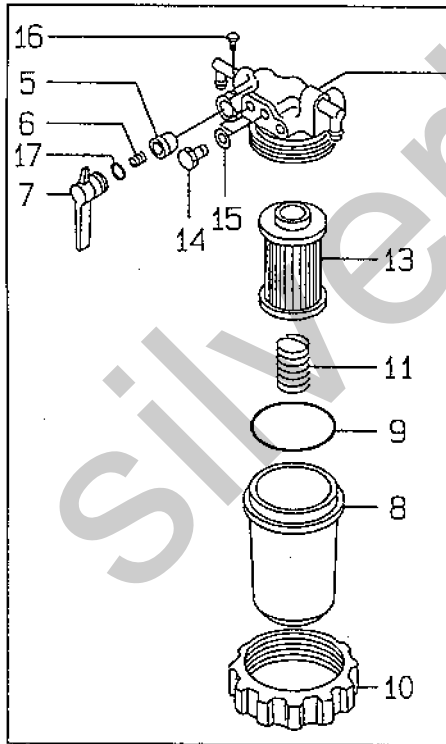
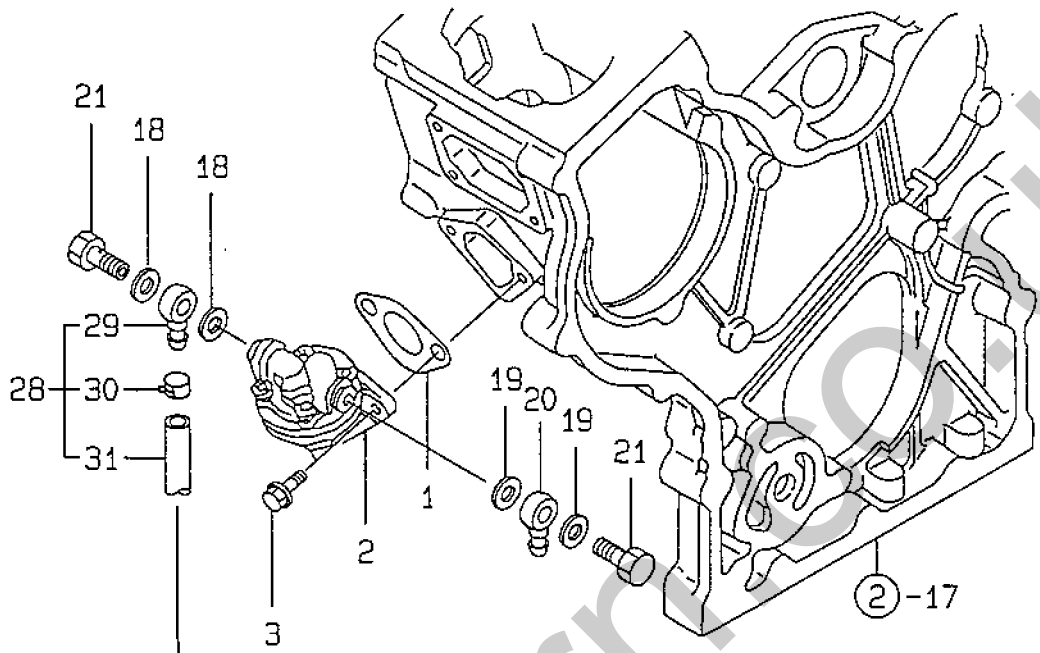

(15) FUEL FILTER

(A)=3TNE68-SA (D)=
 (B)=3TNE68-G1A (E)=
 (C)=3TNE68-G2A (F)=

+-----+
 I 1C01 I
 I(1B01)I
 +-----+
 Y00R4510

REF. NO.	LEV. 0	PART NO.	DESCRIPTION	-----Q'TY-----						I P/U A R
				(A)	(B)	(C)	(D)	(E)	(F)	
1	.	121520-01851	GASKET, (NON-ASB.)	1	1	1				(G)
2	.	119600-52021	PUMP ASSY, FUEL FEED	1	1	1				
3	.	26106-060162	BOLT M 6X 16 PLATED	2	2	2				
4	.	171059-55600	STRAINER ASSY, FUEL	1	1	1				
5	..	104200-55321	VALVE, TAPER	1	1	1				
6	..	104200-55330	SPRING, TAPER VALVE	1	1	1				
7	..	104200-55341	HANDLE, COCK	1	1	1				
8	..	121254-55510	CUP, STRAINER	1	1	1				
9	..	102103-55520	O-RING	1	1	1				
10	..	110250-55610	RING, RETAINING	1	1	1				
11	..	121250-55620	SPRING	1	1	1				
13	..	124550-55700	ELEMENT, FUEL	1	1	1				
14	..	101720-55750	PLUG 6	2	2	2				
15	..	23418-060000	GASKET 6, NYLON	2	2	2				
16	..	104200-55750	SCREW M 4	1	1	1				
17	..	24311-240100	O-RING 1A P-10A	1	1	1				
18	.	22190-080002	SEAL WASHER 8S	2	2	2				(G)
19	.	22190-080002	SEAL WASHER 8S	2	2	2				(G)
20	.	104264-59030	JOINT 8, PIPE	1	1	1				
21	.	105582-59150	BOLT, PIPE JOINT	2	2	2				
22	.	104200-59170	GASKET 12	2	2	2				(G)
23	.	103854-59191	BOLT W/PLUG & SEAL	1	1	1				
25	..	124060-59380	PLUG	1	1	1				
26	..	22190-060002	SEAL WASHER 6S	1	1	1				
27	.	26014-080702	BOLT W/WASHER M8X 70	1	1	1				
28	.	119260-59020	PIPE, FUEL (D12XL400)	1	1	1				
29	..	104264-59030	JOINT 8, PIPE	1	1	1				
30	..	124766-59050	CLAMP 12	2	2	2				
31	..	121236-59080	PIPE, FUEL (D12XL400)	1	1	1				
32	.	119260-59030	PIPE W/JOINT, FUEL	1	1	1				
33	..	101304-59020	JOINT 12, PIPE	1	1	1				
34	..	124766-59050	CLAMP 12	2	2	2				
35	..	105990-59560	PIPE, FUEL	1	1	1				

REMARKS

I (G) THESE PARTS ARE SOLD BY FIG.20,
 I REF.NO.1.

16. ENGINE CONTROL DEVICE

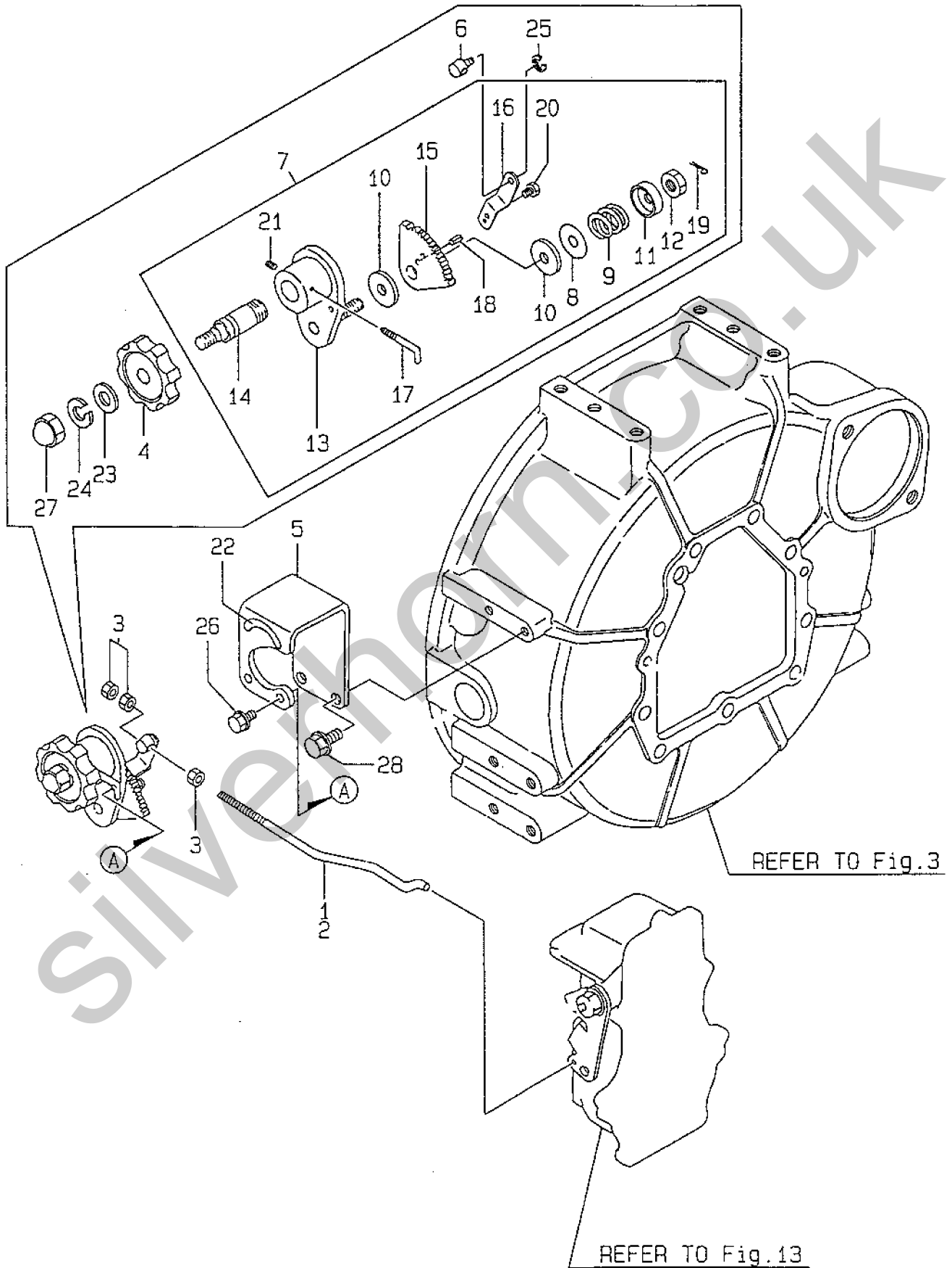

+-----+
I 1C02 I
I (1B01) I
+-----+
Y00R4510

(16) ENGINE CONTROL DEVICE

(A)=3TNE68-SA (D)=
(B)=3TNE68-G1A (E)=
(C)=3TNE68-G2A (F)=

REF. NO.	LEV. 0	PART NO.	DESCRIPTION	-----Q'TY-----						I P/U A R
				(A)	(B)	(C)	(D)	(E)	(F)	
1	.	119288-66120	LINK, ENGINE CONTROL	1	1					
2	.	119288-66160	LINK, ENGINE CONTROL					1		
3	.	26756-050002	LOCK NUT M 5 PLATED	3	3	3				
4	.	126650-66020	HANDLE, REGULATOR	1	1	1				
5	.	119888-66110	BRACKET	1	1	1				
6	.	119888-66130	PIVOT	1	1	1				
7	.	171048-67010	REGULATOR ASSY	1	1	1				
8	..	171102-66080	SPACER	1	1	1				
9	..	104200-66820	SPRING	1	1	1				
10	..	104200-66830	PLATE, FRICTION	2	2	2				
11	..	104200-66850	WASHER (B)	1	1	1				
12	..	104200-66860	NUT	1	1	1				
13	..	171085-67100	BRACKET, GEAR	1	1	1				
14	..	171085-67110	SHAFT, DRIVING	1	1	1				
15	..	171085-67120	GEAR	1	1	1				
16	..	171048-67130	LEVER	1	1	1				
17	..	171048-67140	STOPPER	1	1	1				
18	..	22351-020006	SPRING PIN 2X 6	1	1	1				
19	..	22411-200150	COTTER PIN 2.0X15	1	1	1				
20	..	26116-060082	BOLT M 6X 8 PLATED	1	1	1				
21	..	26921-050122	SCREW M 5X 12	1	1	1				
22	.	170064-67210	LABEL, HANDLE	1	1	1				
23	.	22117-100000	WASHER 10	1	1	1				
24	.	22217-100000	SPRING WASHER 10	1	1	1				
25	.	22272-000050	CIRCLIP E- 5	1	1	1				
26	.	26106-060102	BOLT M 6X 10 PLATED	2	2	2				
27	.	26657-100002	CAP NUT M10	1	1	1				
28	.	26106-080162	BOLT M 8X 16 PLATED	2	2	2				

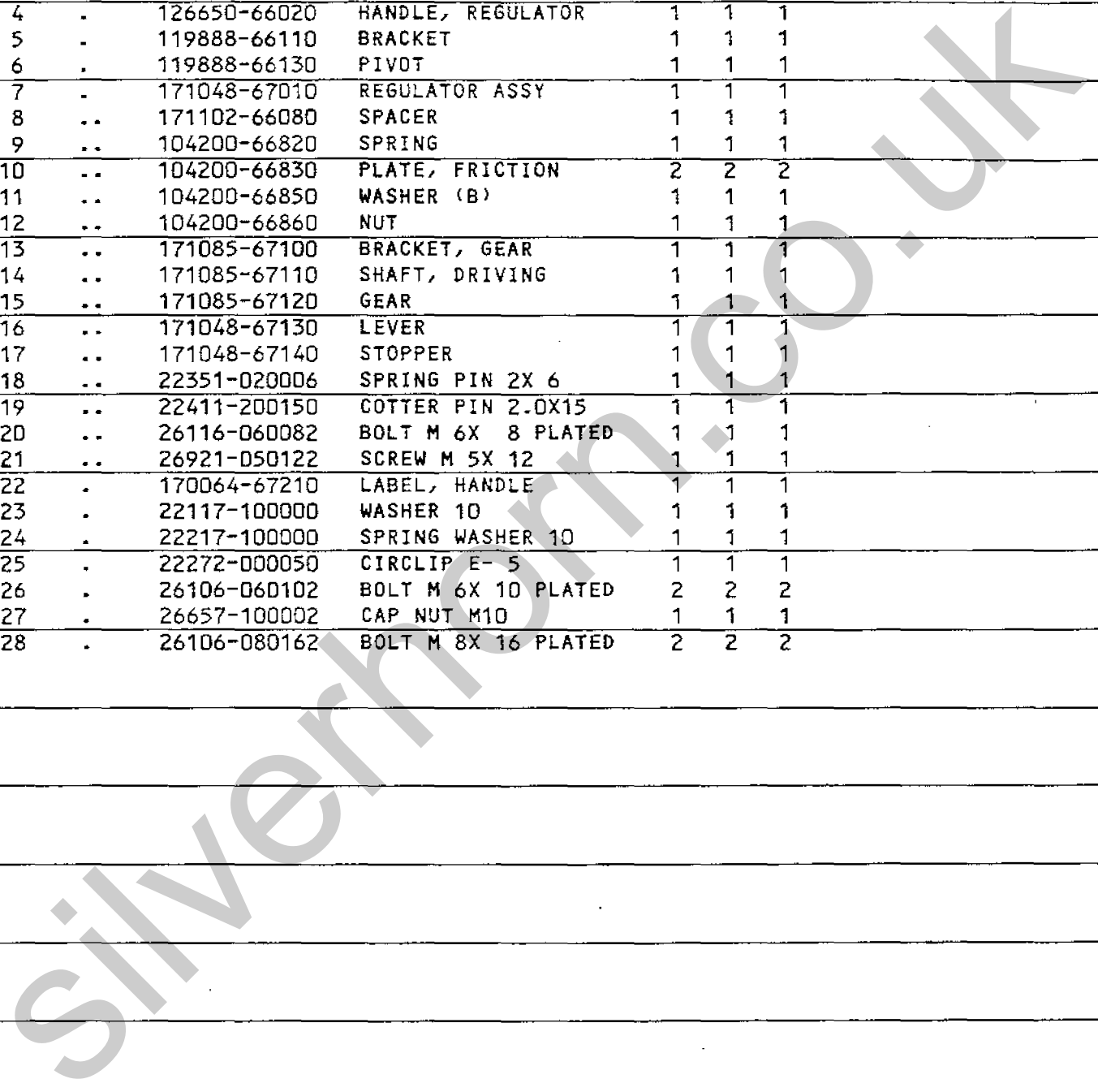

17. STARTING MOTOR

REFER TO Fig.3

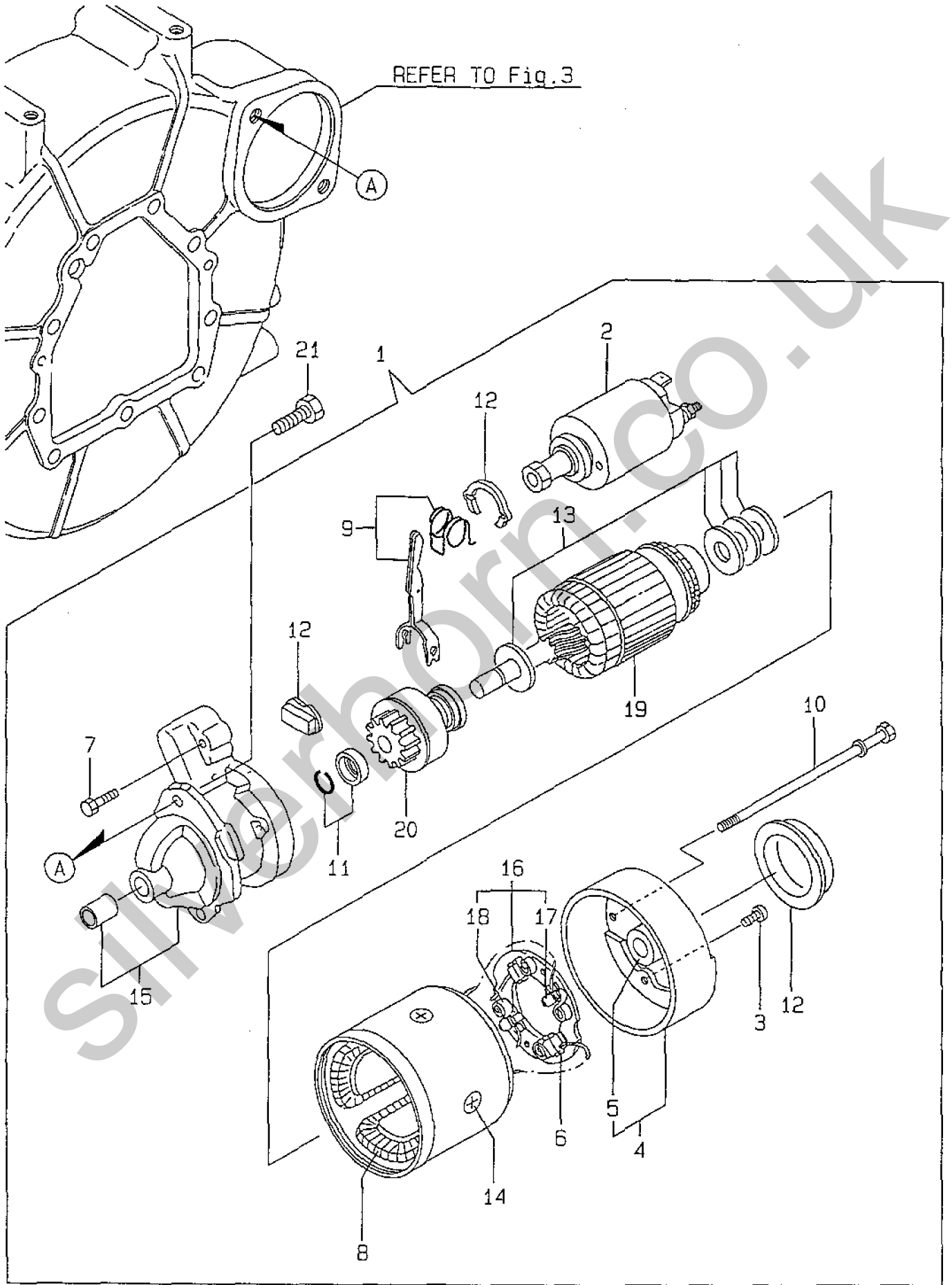

(17) STARTING MOTOR

+-----+
 I 1C03 I
 I(1B01)I
 +-----+
 Y00R4510

(A)=3TNE68-SA (D)=
 (B)=3TNE68-G1A (E)=
 (C)=3TNE68-G2A (F)=

REF. NO.	LEV. 0	PART NO.	DESCRIPTION	-----Q'TY----- I P/U A R					
				(A)	(B)	(C)	(D)	(E)	(F)
1	.	119631-77010	STARTER	1	1	1			
2	..	X2114275070	SWITCH, MAGNETIC	1	1	1			
3	..	X2114283500	SCREW SET	1	1	1			
4	..	X2114430010	COVER ASSY, REAR	1	1	1			
5	...	X2114535200	METAL, STARTER	1	1	1			
6	..	X2114531200	BRUSH (+)	2	2	2			
7	..	X2114586700	BOLT M6X 37	2	2	2			
8	..	X2114631090	COIL ASSY, FIELD	1	1	1			
9	..	X2114660130	LEVER KIT, SHIFT	1	1	1			
10	..	X2114680050	BOLT, THROUGH	2	2	2			
11	..	X2114715500	STOPPER SET, PINION	1	1	1			
12	..	X2114780060	COVER ASSY, DUST	1	1	1			
13	..	X2114811000	WASHER KIT, THRUST	1	1	1			
14	..	X2114821500	SCREW SET	1	1	1			
15	..	X2114966130	CASE ASSY, GEAR	1	1	1			
16	..	X2114990010	HOLDER ASSY, BRUSH	1	1	1			
17	...	X2114831300	BRUSH (-)	1	1	1			
18	...	X2114931400	SPRING, BRUSH	3	3	3			
19	..	124190-77110	ARMATURE, (NON-ASB.)	1	1	1			
20	..	124190-77760	PINION ASSY	1	1	1			
21	.	26116-120252	BOLT M12X 25 PLATED	2	2	2			

18. GENERATOR

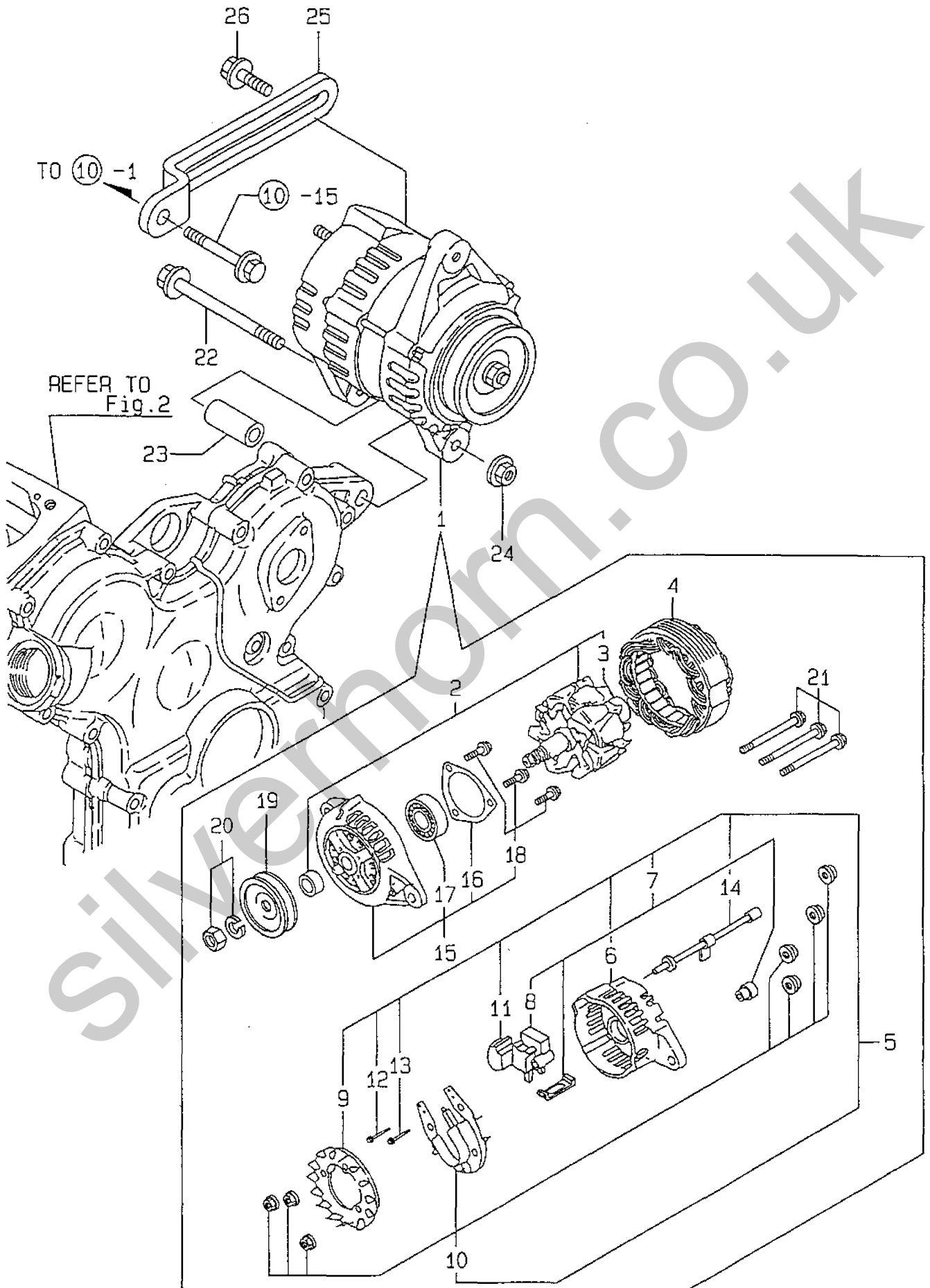

(18) GENERATOR

(A)=3TNE68-SA (D)=
 (B)=3TNE68-61A (E)=
 (C)=3TNE68-62A (F)=

+-----+
 I 1C04 I
 I(1B01)I
 +-----+
 Y00R4510

REF. NO.	LEV. 0	PART NO.	DESCRIPTION	-----Q'TY----- I P/U A R					
				(A)	(B)	(C)	(D)	(E)	(F)
1	.	119836-77200	GENERATOR	1	1	1			
2	..	119836-77700	ROTOR ASSY	1	1	1			
3	...	119836-77850	BALL BEARING	1	1	1			
4	..	119836-77710	STARTER ASSY	1	1	1			
5	..	119836-77721	COVER ASSY, REAR	1	1	1			
6	...	119836-77730	COVER, REAR	1	1	1			
7	...	119836-77741	BRUSH ASSY,REGULATOR	1	1	1			
8	119836-77750	BRUSH ASSY	1	1	1			
9	...	119836-77760	GUIDE, FAN SIDE	1	1	1			
10	...	119836-77770	DIODE ASSY	1	1	1			
11	...	119836-77780	CONDENSER	1	1	1			
12	...	119836-77871	BOLT (1)	1	1	1			
13	...	119836-77880	BOLT (2)	1	1	1			
14	...	119836-77890	WIRE ASSY, LEAD	1	1	1			
15	..	119836-77790	COVER ASSY, FRONT	1	1	1			
16	...	119836-77800	RETAINER, BEARING	1	1	1			
17	...	119836-77840	BALL BEARING	1	1	1			
18	...	119836-77860	SCREW KID	1	1	1			
19	..	119836-77810	PULLEY	1	1	1			
20	..	119836-77820	NUT ASSY, PULLEY	1	1	1			
21	..	119836-77830	BOLT, THROUGH	1	1	1			
22	.	26106-081052	BOLT M 8X105 PLATED	1	1	1			
23	.	129150-77340	SPACER	1	1	1			
24	.	26366-080002	NUT M 8	1	1	1			
25	.	119225-77330	ADJUSTER, BELT	1	1	1			
26	.	26106-080182	BOLT M 8X 18 PLATED	1	1	1			

19. PANEL

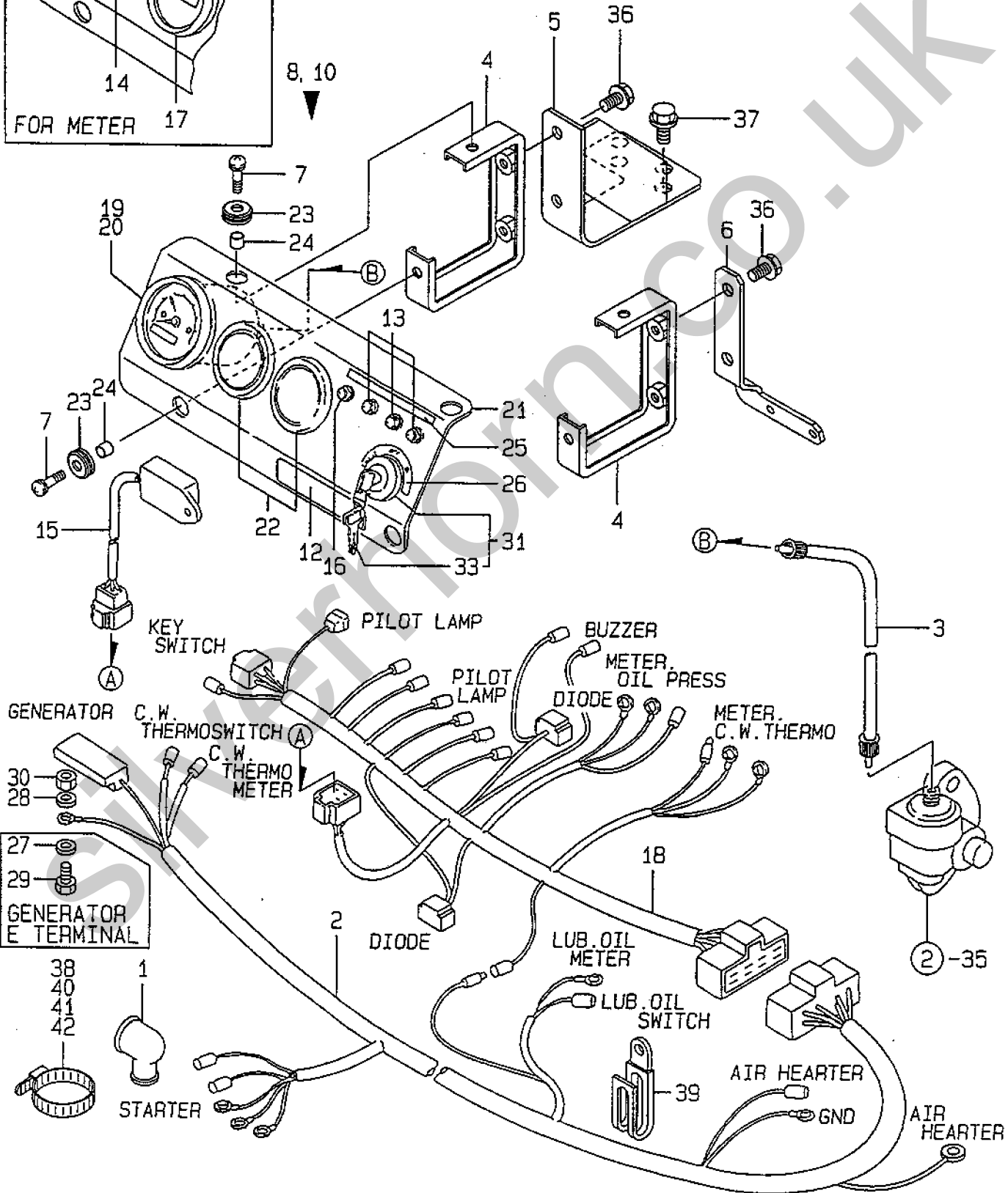
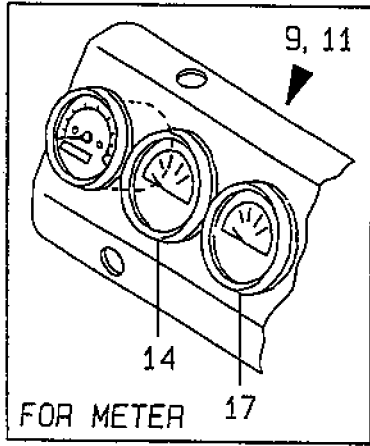

(19) PANEL

(A)=3TNE68-SA (D)=
 (B)=3TNE68-G1A (E)=
 (C)=3TNE68-G2A (F)=

-----+
 I 1C05 I
 I(1B01)I
 -----+
 Y00R4510

REF. NO.	LEV. 0	PART NO.	DESCRIPTION	-----Q'TY-----						I P/U A R
				(A)	(B)	(C)	(D)	(E)	(F)	
1	.	124550-77030	COVER, TERMINAL	1	1	1				
2	.	119888-91021	HARNESS (A), WIRE	1	1	1				
3	.	124701-91140	CABLE L= 985	1	1	1				
4	.	119888-91120	SUPPORT, PANEL	2	2	2				
5	.	119288-91130	BRACKET	1	1	1				
6	.	119288-91140	SUPPORT	1	1	1				
7	.	26033-060202	SCREW M 6X 20	4	4	4				
8	.	119888-91101	PANEL ASSY, INSTRUM	1		1				
9	.	119888-91201	PANEL ASSY, INSTRUM	1		1				(1)
10	.	119888-91301	PANEL ASSY, INSTRUM		1					
11	.	119888-91311	PANEL ASSY, INSTRUM		1					(1)
12	..	104507-07190	LABEL, YANMAR	1	1	1				
13	..	124732-77720	LAMP, CHARGING	3	3	3				
14	..	171010-77850	THERMOMETER, C.W.	1	1	1				
15	..	128300-77920	TIMER	1	1	1				
16	..	124559-77971	LAMP, PILOT	1	1	1				
17	..	171090-91010	GAUGE, PRESSURE	1	1	1				
18	..	119888-91031	HARNESS (B), WIRE	1	1	1				
19	..	171080-91100	TACHOMETER	1		1				
20	..	171082-91100	TACHOMETER		1					
21	..	119888-91110	BODY, CONT. PANEL	1	1	1				
22	..	124770-91220	COVER 52	2	2	2				
23	..	121400-91520	ABSORBER	4	4	4				
24	..	121400-91530	SPACER	4	4	4				
25	..	119888-91610	LABEL, CW & OIL LAMP	1	1	1				
26	..	119888-91620	LABEL, KEY SWITCH	1	1	1				
27	..	22117-050000	WASHER 5	1		1				
28	..	22117-050000	WASHER 5	1		1				
29	..	26116-050102	BOLT M 5X 10 PLATED	1		1				
30	..	26716-050002	NUT M 5	1		1				
31	..	933110-00100	SWITCH ASSY, STARTER	1	1	1				
33	...	933110-00301	KEY ASSY	1	1	1				
36	.	26106-080122	BOLT M 8X 12 PLATED	4	4	4				
37	.	26106-100502	BOLT M10X 50 PLATED	2	2	2				
38	.	121750-59890	RETAINER	1	1	1				
39	.	194180-51640	CLAMP, WIRE HARNESS	1	1	1				
40	.	121750-59890	RETAINER	1	1					
41	.	121750-59890	RETAINER			1				
42	.	121750-59890	RETAINER	1	1					

----- REMARKS -----

I (1) WITH C.W.THERMOMETER (REF.NO.14,
 I P/# 171010-77850) & PRESSURE
 I GAUGE (REF.NO.17, P/# 171090-91010).

20. GASKET SET

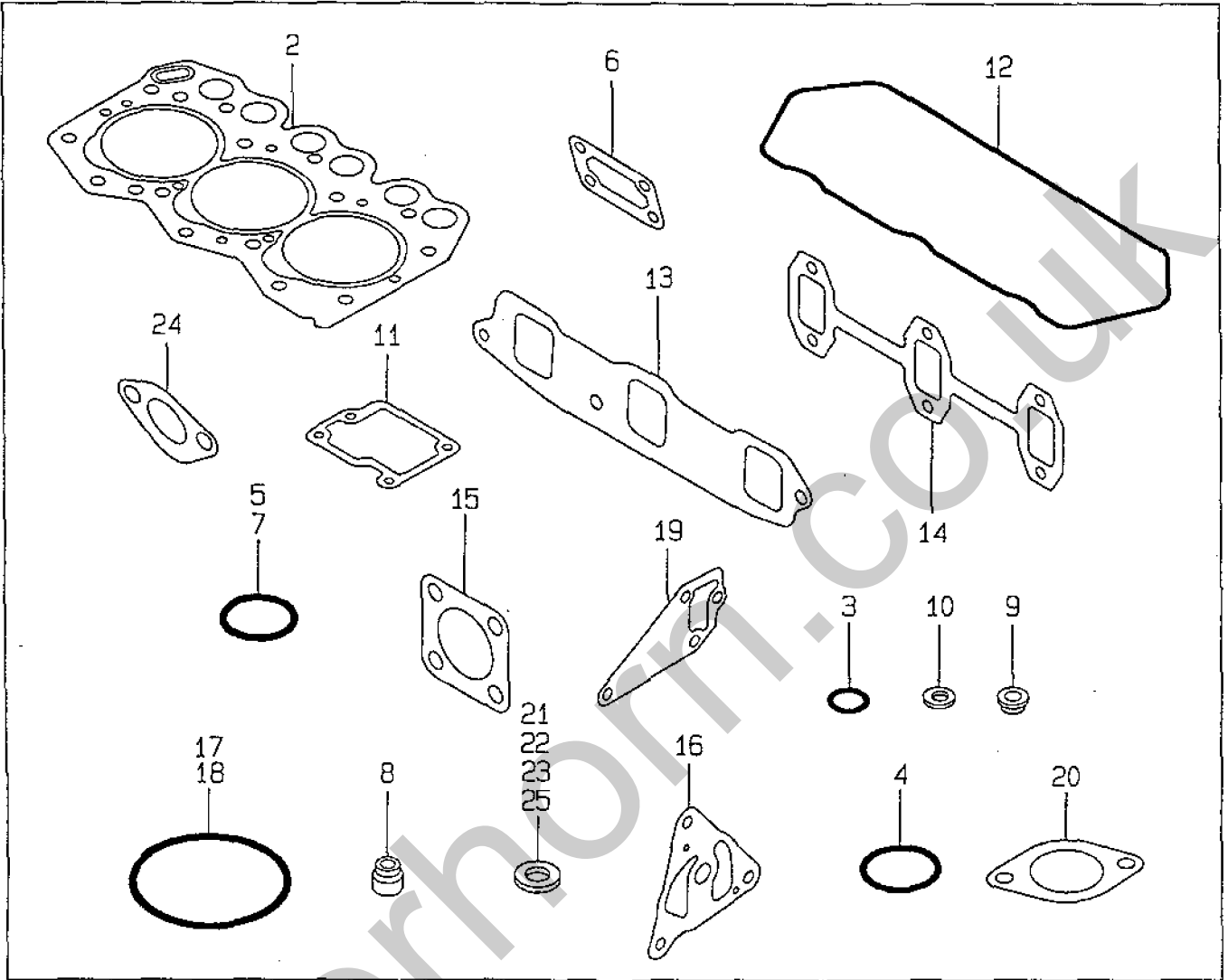

1

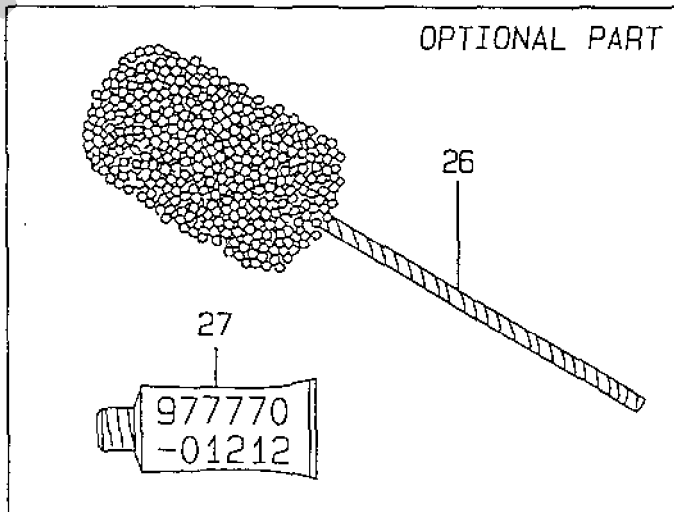

(20) GASKET SET

(A)=3TNE68-SA (D)=
 (B)=3TNE68-G1A (E)=
 (C)=3TNE68-G2A (F)=

+-----+
 I 1006 I
 I(1B01)I
 +-----+
 Y00R4510

REF. NO.	LEV. 0	PART NO.	DESCRIPTION	-----Q'TY----- I P/U A R						
				(A)	(B)	(C)	(D)	(E)	(F)	
1	.	719265-92611	GASKET SET	1	1	1				(1)
2	..	119265-01340	GASKET, CYL. HEAD	1	1	1				
3	..	24311-000120	O-RING 1A P 12.0	5	5	5				
4	..	24311-000320	O-RING 1A P-32.0	2	2	2				
5	..	24341-000240	O-RING 1A S-24.0	1	1	1				
6	..	119660-01562	GASKET, (NON-ASB.)	1	1	1				
7	..	24311-000180	O-RING 1A P-18.0	1	1	1				
8	..	119260-11340	SEAL, VALVE STEM	6	6	6				
9	..	119600-11450	PROTECTOR, NOZZLE	3	3	3				
10	..	119600-11460	GASKET, NOZZLE	6	6	6				
11	..	119260-03031	GASKET, (NON-ASB.)	1	1	1				
12	..	119260-11310	GASKET, BONNET	1	1	1				
13	..	119270-12110	GASKET, SUC.MANIFOLD	1	1	1				
14	..	119260-13110	GASKET, EXH.MANIFOLD	1	1	1				
15	..	121000-13201	GASKET, SILENCER	2	2	2				
16	..	119660-32020	GASKET, L.O.PUMP	1	1	1				
17	..	24321-000600	O-RING 1A G-60.0	1	1	1				
18	..	24321-000700	O-RING 1A G-70.0	1	1	1				
19	..	119260-42020	GASKET, C.W. PUMP	1	1	1				
20	..	129350-49541	GASKET, (NON-ASB.)	1	1	1				
21	..	124465-44950	GASKET 16	2	2	2				
22	..	22190-080002	SEAL WASHER 8S	4	4	4				
23	..	23414-140000	GASKET 14, ROUND	3	3	3				
24	..	121520-01851	GASKET, (NON-ASB.)	1	1	1				
25	..	104200-59170	GASKET 12	2	2	2				
26	.	129400-92400	FLEX HORN	1	1	1				(1)
27	.	977770-01212	GASKET, LIQUID	1	1	1				(1)

REMARKS

I(1) OPTIONAL PART.

Y100556

PART NO.	DESCRIPTION	CATALOG NO.	GRP. NO.	REF. NO.	LOC. NO.	PART NO.	DESCRIPTION	CATALOG NO.	GRP. NO.	REF. NO.	LOC. NO.
X2114275070	SWITCH, MAGNETIC	YDOR4510	17	2	1C03	119253-13100	MANIFOLD, EXHAUST	YDOR4510	6	1	1B07
X2114283500	SCREW SET	YDOR4510	17	3	1C03	119256-42290	V-BELT 33.5	YDOR4510	10	17	1B11
X2114430010	COVER ASSY, REAR	YDOR4510	17	4	1C03	119259-44570	CAP, RADIATOR	YDOR4510	11	5	1B12
X2114531200	BRUSH (+)	YDOR4510	17	6	1C03	119260-01200	BOLT, CYL HEAD	YDOR4510	1	23	1B02
X2114535200	METAL, STARTER	YDOR4510	17	5	1C03	119260-01490	HOUSING ASSY, GEAR	YDOR4510	2	17	1B03
X2114586700	BOLT M6X 37	YDOR4510	17	7	1C03	119260-01510	PLUG	YDOR4510	2	20	1B03
X2114631090	COIL ASSY, FIELD	YDOR4510	17	8	1C03	119260-01590	COVER ASSY, GEAR CASE	YDOR4510	2	1	1B03
X2114660130	LEVER KIT, SHIFT	YDOR4510	17	9	1C03	119260-01770	SUMP ASSY, OIL	YDOR4510	3	17	1B04
X2114680050	BOLT, THROUGH	YDOR4510	17	10	1C03	119260-02020	BOLT	YDOR4510	1	6	1B02
X2114715500	STOPPER SET, PINION	YDOR4510	17	11	1C03	119260-02410	BUSH, CAMSHAFT	YDOR4510	1	22	1B02
X2114780060	COVER ASSY, DUST	YDOR4510	17	12	1C03	119260-02800	MAIN BEARING	YDOR4510	1	16	1B02
X2114811000	WASHER KIT, THRUST	YDOR4510	17	13	1C03	119260-02930	THRUST BEARING	YDOR4510	1	19	1B02
X2114821500	SCREW SET	YDOR4510	17	14	1C03	119260-03020	PLATE, SHELTER	YDOR4510	4	57	1B05
X2114831300	BRUSH (-)	YDOR4510	17	17	1C03	119260-03031	GASKET, (NON-ASB.)	YDOR4510	4	58	1B05
X2114931400	SPRING, BRUSH	YDOR4510	17	18	1C03				20	11	1C06
X2114966130	CASE ASSY, GEAR	YDOR4510	17	15	1C03	119260-07900	LIFTER, ENGINE	YDOR4510	4	7	1B05
X2114990010	HOLDER ASSY, BRUSH	YDOR4510	17	16	1C03	119260-11100	VALVE, SUCTION	YDOR4510	4	20	1B05
101304-59020	JOINT 12, PIPE	YDOR4510	15	33	1C01	119260-11110	VALVE, EXHAUST	YDOR4510	4	21	1B05
101720-55750	PLUG 6	YDOR4510	15	14	1C01	119260-11200	SUPPORT ASSY, ARM	YDOR4510	4	30	1B05
102103-55520	O-RING	YDOR4510	15	9	1C01	119260-11240	SHAFT ASSY, ARM	YDOR4510	4	32	1B05
103854-59191	BOLT W/PLUG & SEAL	YDOR4510	15	23	1C01	119260-11260	SUPPORT, ROCKER ARM	YDOR4510	4	35	1B05
104200-55321	VALVE, TAPER	YDOR4510	15	5	1C01	119260-11270	SCREW	YDOR4510	4	36	1B05
104200-55330	SPRING, TAPER VALVE	YDOR4510	15	6	1C01	119260-11280	SPRING	YDOR4510	4	37	1B05
104200-55341	HANDLE, COCK	YDOR4510	15	7	1C01	119260-11310	GASKET, BONNET	YDOR4510	4	61	1B05
104200-55750	SCREW M 4	YDOR4510	15	16	1C01				20	12	1C06
104200-59170	GASKET 12	YDOR4510	15	22	1C01	119260-11330	BONNET ASSY, (NON-ASB)	YDOR4510	4	55	1B05
			20	25	1C06	119260-11340	SEAL, VALVE STEM	YDOR4510	4	26	1B05
104200-66820	SPRING	YDOR4510	16	9	1C02				20	8	1C06
104200-66830	PLATE, FRICTION	YDOR4510	16	10	1C02	119260-11370	CAP, VALVE	YDOR4510	4	27	1B05
104200-66850	WASHER (B)	YDOR4510	16	11	1C02	119260-11800	GUIDE, VALVE	YDOR4510	4	14	1B05
104200-66860	NUT	YDOR4510	16	12	1C02	119260-13110	GASKET, EXH.MANIFOLD	YDOR4510	6	2	1B07
104264-59030	JOINT 8, PIPE	YDOR4510	15	20	1C01				20	14	1C06
			29		1C01	119260-14100	GEAR, CAMSHAFT	YDOR4510	7	7	1B08
104507-07190	LABEL, YANMAR	YDOR4510	19	12	1C05	119260-14200	TAPPET	YDOR4510	7	1	1B08
104514-42780	V-BELT (HM-33)	YDOR4510	10	16	1B11	119260-14400	ROD, PUSH	YDOR4510	7	2	1B08
105010-11230	SCREW, VALVE	YDOR4510	4	40	1B05	119260-14580	CAMSHAFT ASSY	YDOR4510	7	3	1B08
			46		1B05	119260-21200	GEAR, CRANKSHAFT	YDOR4510	8	5	1B09
105546-51330	SPRING, DELIV. VALVE	YDOR4510	12	25	1B13	119260-21650	V-PULLEY	YDOR4510	8	8	1B09
105582-59150	BOLT, PIPE JOINT	YDOR4510	15	21	1C01	119260-23910	BUSH, PISTON PIN	YDOR4510	8	41	1B09
105990-59560	PIPE, FUEL	YDOR4510	15	35	1C01	119260-25100	GEAR W/BUSH, IDLE	YDOR4510	7	11	1B08
110250-55610	RING, RETAINING	YDOR4510	15	10	1C01	119260-32000	PUMP ASSY, LUB. OIL	YDOR4510	9	4	1B10
114250-11120	SPRING, VALVE	YDOR4510	4	22	1B05	119260-34810	GUIDE, DIPSTICK	YDOR4510	9	34	1B10
114250-11180	RETAINER, SPRING	YDOR4510	4	23	1B05	119260-35081	PIPE ASSY, OIL INTAKE	YDOR4510	9	25	1B10
114250-53130	SEAT, NOZZLE SPRING	YDOR4510	14	9	1B16	119260-42020	GASKET, C.W. PUMP	YDOR4510	10	13	1B11
114250-53400	SHIM PACK	YDOR4510	14	11	1B16				20	19	1C06
119225-14200	CAM ASSY, F.I. PUMP	YDOR4510	7	18	1B08	119260-59020	PIPE, FUEL (D12XL400)	YDOR4510	15	28	1C01
119225-34810	GUIDE, DIPSTICK	YDOR4510	9	33	1B10	119260-59030	PIPE W/JOINT, FUEL	YDOR4510	15	32	1C01
119225-35300	VALVE ASSY, OIL PRESS	YDOR4510	9	14	1B10	119260-59520	JOINT (B)	YDOR4510	14	39	1B16
119225-51100	PLUNGER W/BARREL	YDOR4510	12	4	1B13	119260-59530	JOINT (A)	YDOR4510	14	37	1B16
119225-51300	VALVE W/SEAT, DELIV.	YDOR4510	12	22	1B13	119260-59540	PIPE ASSY, FUEL OVER	YDOR4510	14	35	1B16
119225-59810	PIPE (1), FUEL INJECT	YDOR4510	14	23	1B16	119260-59550	PIPE, FUEL	YDOR4510	14	38	1B16
119225-77330	ADJUSTER, BELT	YDOR4510	18	25	1C04	119260-59820	PIPE (2), FUEL INJECT	YDOR4510	14	27	1B16
119232-61510	LEVER ASSY, GOVERNOR	YDOR4510	13	29	1B14	119260-59830	PIPE (3), FUEL INJECT	YDOR4510	14	31	1B16
119232-61540	SPRING, LEVER	YDOR4510	13	45	1B14	119260-66010	SPRING, REGULATOR	YDOR4510	13	66	1B14

PART NO.	DESCRIPTION	CATALOG NO.	GRP. NO.	REF. NO.	LOC. NO.	PART NO.	DESCRIPTION	CATALOG NO.	GRP. NO.	REF. NO.	LOC. NO.
119260-66720	ANGLEICH ASSY	YOOR4510	13	85	1B14	119610-66700	ANGLEICH ASSY	YOOR4510	13	84	1B14
119265-01340	GASKET, CYL. HEAD	YOOR4510	1	24	1B02	119620-01620	PARALLEL PIN 6X10	YOOR4510	3	10	1B04
			20	2	1C06	119620-01621	STUD, STARTER	YOOR4510	3	9	1B04
119265-11700	HEAD ASSY, CYLINDER	YOOR4510	4	10	1B05	119620-01750	CAP, FLYWHEEL COVER	YOOR4510	3	7	1B04
119265-21700	CRANKSHAFT ASSY	YOOR4510	8	1	1B09	119620-01800	SEAL HTC456208, OIL	YOOR4510	2	4	1B03
119265-22090	PISTON W/RINGS	YOOR4510	8	26	1B09	119620-02450	BEARING, THRUST	YOOR4510	7	4	1B08
119265-22300	PIN, PISTON	YOOR4510	8	35	1B09	119620-11350	STUD	YOOR4510	4	51	1B05
119265-22500	RING SET	YOOR4510	8	29	1B09	119620-11390	JOINT	YOOR4510	4	62	1B05
119265-22601	PISTON W/RINGS	YOOR4510	8	25	1B09	119620-13501	SILENCER	YOOR4510	6	12	1B07
119265-22900	PISTON ASSY O.S=0.25	YOOR4510	8	46	1B09	119620-13510	MUFFLER BODY ASSY	YOOR4510	6	13	1B07
119265-22930	PISTON W/RING OS=.25	YOOR4510	8	45	1B09	119620-13520	TAILPIPE ASSY	YOOR4510	6	14	1B07
119265-22950	RING SET O.S=0.25	YOOR4510	8	49	1B09	119620-13560	TAILPIPE	YOOR4510	6	15	1B07
119265-23100	ROD ASSY, CONNECTING	YOOR4510	8	37	1B09	119620-21500	BOLT, FLYWHEEL	YOOR4510	8	20	1B09
119265-23200	BOLT, ROD	YOOR4510	8	42	1B09	119620-21591	FLYWHEEL W/RING GEAR	YOOR4510	8	21	1B09
119265-35300	VALVE ASSY, OIL PRESS	YOOR4510	9	15	1B10	119620-21941	WASHER	YOOR4510	8	10	1B09
119265-42002	PUMP ASSY, C. WATER	YOOR4510	10	1	1B11	119620-25912	BUSH	YOOR4510	7	13	1B08
119265-44940	RETAINING BAR	YOOR4510	11	8	1B12	119620-34822	DIPSTICK, LUB. OIL	YOOR4510	9	35	1B10
119270-12100	MANIFOLD, SUCTION	YOOR4510	5	1	1B06	119620-42350	V-PULLEY, C.W. PUMP	YOOR4510	10	18	1B11
119270-12110	GASKET, SUC.MANIFOLD	YOOR4510	5	2	1B06	119620-51170	RETAINER	YOOR4510	12	7	1B13
			20	13	1C06	119620-51180	RETAINER	YOOR4510	12	8	1B13
119280-01600	FLANGE, MOUNTING	YOOR4510	3	2	1B04	119620-51190	SPRING, PLUNGER	YOOR4510	12	9	1B13
119280-49020	PIPE (B), C. WATER	YOOR4510	11	33	1B12	119620-51250	SHIM PACK	YOOR4510	12	10	1B13
119285-66080	SHAFT ASSY, REGULATOR	YOOR4510	13	56	1B14	119620-51340	HOLDER, DELIV. VALVE	YOOR4510	12	26	1B13
119288-08100	BRACKET (A), ENGINE	YOOR4510	11	1	1B12	119620-51350	GASKET, DELIVERY	YOOR4510	12	27	1B13
119288-49010	PIPE A, COOLING WATER	YOOR4510	11	31	1B12	119620-51370	O-RING	YOOR4510	12	28	1B13
119288-55900	BRACKET, FUEL FILTER	YOOR4510	13	123	1B15	119620-51450	GUIDE, PLUNGER	YOOR4510	12	29	1B13
119288-61200	CASE ASSY, GOVERNOR	YOOR4510	13	15	1B14	119620-51461	PIN	YOOR4510	12	30	1B13
119288-61510	LEVER ASSY, GOVERNOR	YOOR4510	13	30	1B14	119620-51510	PINION	YOOR4510	12	32	1B13
119288-66120	LINK, ENGINE CONTROL	YOOR4510	16	1	1C02	119620-51650	PLATE	YOOR4510	12	34	1B13
119288-66160	LINK, ENGINE CONTROL	YOOR4510	16	2	1C02	119620-51660	SCREW	YOOR4510	12	35	1B13
119288-91130	BRACKET	YOOR4510	19	5	1C05	119620-51670	PIN	YOOR4510	12	36	1B13
119288-91140	SUPPORT	YOOR4510	19	6	1C05	119620-51680	PIN	YOOR4510	12	37	1B13
119305-35150	FILTER, LUB. OIL	YOOR4510	9	13	1B10	119620-51700	TAPPET ASSY	YOOR4510	12	38	1B13
119358-13640	RAINCAP, MUFFLER	YOOR4510	6	17	1B07	119620-53000	NOZZLE ASSY, F. INJECT	YOOR4510	14	3	1B16
119454-01721	SPACER, OIL SUMP	YOOR4510	3	15	1B04	119620-53080	NUT, VALVE W/CASE	YOOR4510	14	6	1B16
119462-12550	PIPE, SUCTION	YOOR4510	5	11	1B06	119620-53100	HOLDER, VALVE W/CASE	YOOR4510	14	7	1B16
119489-11200	SUPPORT ASSY, ARM	YOOR4510	4	31	1B05	119620-53120	SPRING, VALVE	YOOR4510	14	8	1B16
119489-12600	SUPPORT, AIR CLEANER	YOOR4510	5	5	1B06	119620-53140	SPACER, VALVE STOP	YOOR4510	14	10	1B16
119489-66010	SPRING, REGULATOR	YOOR4510	13	65	1B14	119620-59700	NUT	YOOR4510	14	40	1B16
119600-01600	HOUSING, FLYWHEEL	YOOR4510	3	3	1B04	119620-77820	CONNECTOR, GLOW PLUG	YOOR4510	4	68	1B05
119600-11450	PROTECTOR, NOZZLE	YOOR4510	4	28	1B05	119621-01611	REAR PLATE	YOOR4510	3	4	1B04
			20	9	1C06	119621-21680	BOLT M12X1.25, FLANGE	YOOR4510	8	9	1B09
119600-11460	GASKET, NOZZLE	YOOR4510	4	29	1B05	119621-44500	RADIATOR	YOOR4510	11	4	1B12
			20	10	1C06	119621-44560	FAN-GUARD	YOOR4510	11	6	1B12
119600-21580	FLYWHEEL ASSY	YOOR4510	8	16	1B09	119621-66051	LEVER, REGULATOR	YOOR4510	13	67	1B14
119600-52021	PUMP ASSY, FUEL FEED	YOOR4510	15	2	1C01	119623-01950	SHIM PACK	YOOR4510	2	26	1B03
119600-61100	DRIVING SET, GOV.	YOOR4510	13	4	1B14	119629-66510	TORQUE SPRING ASSY	YOOR4510	13	76	1B14
119600-61200	WEIGHT ASSY, GOV.	YOOR4510	13	5	1B14	119631-77010	STARTER	YOOR4510	17	1	1C03
119600-61541	SHIFTER, P.T.O.	YOOR4510	13	46	1B14	119632-61200	CASE ASSY, GOVERNOR	YOOR4510	13	14	1B14
119600-61650	SPRING, STARTING	YOOR4510	13	50	1B14	119642-33030	COOLER, OIL	YOOR4510	9	39	1B10
119600-61900	RETAINER, SHAFT	YOOR4510	13	54	1B14	119642-33100	BRACKET	YOOR4510	9	40	1B10
119600-66020	SPRING, REGULATOR	YOOR4510	13	64	1B14	119642-49030	PIPE	YOOR4510	9	43	1B10
119600-66530	TORQUE SPRING ASSY	YOOR4510	13	75	1B14	119645-49020	PIPE (B), C. WATER	YOOR4510	11	32	1B12
119600-66840	NUT, CAP	YOOR4510	13	113	1B14	119653-12500	CLEANER ASSY, AIR	YOOR4510	5	6	1B06

PART NO.	DESCRIPTION	CATALOG NO.	GRP. NO.	REF. NO.	LOC NO.	PART NO.	DESCRIPTION	CATALOG NO.	GRP. NO.	REF. NO.	LOC NO.	
119653-66500	ENGINE STOP DEVICE	YOOR4510	13	69	1B14	119836-77880	BOLT (2)	YOOR4510	18	13	1C04	
119654-66700	ANGLEIGH ASSY	YOOR4510	13	83	1B14	119836-77890	WIRE ASSY, LEAD	YOOR4510	18	14	1C04	
119655-12560	ELEMENT	YOOR4510	5	8	1B06	119840-13150	PIPE, EXHAUST	YOOR4510	6	3	1B07	
119660-01551	COVER	YOOR4510	2	23	1B03	119865-12600	STAY	YOOR4510	5	12	1B06	
119660-01562	GASKET, (NON-ASB.)	YOOR4510	2	24	1B03	119865-21600	GEAR, RING	YOOR4510	8	15	1B09	
			20	6	1C06					19	1B09	
119660-01570	STUD M6X12	YOOR4510	2	25	1B03	119888-08110	BRACKET (B), ENGINE	YOOR4510	11	2	1B12	
119660-01640	CASE ASSY, OIL SEAL	YOOR4510	3	11	1B04	119888-66110	BRACKET	YOOR4510	16	5	1C02	
119660-01821	BEARING, FUEL CAM.	YOOR4510	7	17	1B08	119888-66130	PIVOT	YOOR4510	16	6	1C02	
119660-01911	PIPE, KNOCK	YOOR4510	2	5	1B03	119888-91021	HARNES (A), WIRE	YOOR4510	19	2	1C05	
119660-25022	RETAINER, IDLE GEAR	YOOR4510	7	9	1B08	119888-91031	HARNES (B), WIRE	YOOR4510	19	18	1C05	
119660-25052	SHAFT, IDLE GEAR	YOOR4510	7	10	1B08	119888-91101	PANEL ASSY, INSTRUM	YOOR4510	19	8	1C05	
119660-32020	GASKET, L.O.PUMP	YOOR4510	9	11	1B10	119888-91110	BODY, CONT. PANEL	YOOR4510	19	21	1C05	
			20	16	1C06	119888-91120	SUPPORT, PANEL	YOOR4510	19	4	1C05	
119660-51500	RACK	YOOR4510	12	31	1B13	119888-91201	PANEL ASSY, INSTRUM	YOOR4510	19	9	1C05	
119660-51530	RETAINER, RACK	YOOR4510	12	33	1B13	119888-91301	PANEL ASSY, INSTRUM	YOOR4510	19	10	1C05	
119660-61052	GASKET, (NON-ASB.)	YOOR4510	13	19	1B14	119888-91311	PANEL ASSY, INSTRUM	YOOR4510	19	11	1C05	
119660-61060	COVER, GOVERNOR CASE	YOOR4510	13	2	1B14	119888-91610	LABEL, CW & OIL LAMP	YOOR4510	19	25	1C05	
119660-61071	GASKET, (NON-ASB.)	YOOR4510	13	3	1B14	119888-91620	LABEL, KEY SWITCH	YOOR4510	19	26	1C05	
119660-61121	LINK L=88.8(INO COLOR)	YOOR4510	13	11	1B14	121000-13201	GASKET, SILENCER	YOOR4510	6	4	1B07	
119660-61140	LINK L=88.6(WHITE)	YOOR4510	13	12	1B14					11	1B07	
119660-61150	LINK L=89.0(RED)	YOOR4510	13	13	1B14					20	1C06	
119660-61300	NUT, GOVERNOR WEIGHT	YOOR4510	13	9	1B14	121023-01550	COVER, BLIND	YOOR4510	2	14	1B03	
119660-61341	SLEEVE, GOVERNOR	YOOR4510	13	10	1B14	121023-49150	HOSE, WATER DRAIN 165	YOOR4510	11	41	1B12	
119660-61460	SHIM SET	YOOR4510	13	20	1B14	121111-21501	BOLT, FLYWHEEL	YOOR4510	8	11	1B09	
119660-61491	SHAFT, GOVERNOR LEVER	YOOR4510	13	28	1B14	121120-01620	BOLT M 10X 28	YOOR4510	3	5	1B04	
119660-61651	SPRING, STARTING	YOOR4510	13	49	1B14	121236-59080	PIPE, FUEL (Ø12XL400)	YOOR4510	15	31	1C01	
119660-61901	RETAINER, SHAFT	YOOR4510	13	55	1B14	121250-44901	SWITCH, THERMO(110°C)	YOOR4510	10	28	1B11	
119688-21590	FLYWHEEL CMP	YOOR4510	8	12	1B09	121250-55620	SPRING	YOOR4510	15	11	1C01	
119688-44950	BRACKET (A)	YOOR4510	11	9	1B12	121254-55510	CUP, STRAINER	YOOR4510	15	8	1C01	
119688-44961	BRACKET (B), RADIATOR	YOOR4510	11	10	1B12	121256-44600	BRACKET, SUB-TANK	YOOR4510	11	29	1B12	
119688-44971	BRACKET (L)	YOOR4510	11	11	1B12	121267-44760	SPACER	YOOR4510	10	21	1B11	
119688-44981	BRACKET (R)	YOOR4510	11	12	1B12	121400-01640	PLUG M16	YOOR4510	3	18	1B04	
119688-49010	PIPE (A), C. WATER	YOOR4510	11	30	1B12	121400-44650	ABSORBER, SHOCK	YOOR4510	11	7	1B12	
119808-12540	VALVE, UNLOADER	YOOR4510	5	10	1B06	121400-91520	ABSORBER	YOOR4510	19	23	1C05	
119836-77200	GENERATOR	YOOR4510	18	1	1C04	121400-91530	SPACER	YOOR4510	19	24	1C05	
119836-77700	ROTOR ASSY	YOOR4510	18	2	1C04	121450-01560	STUD M 8X 22	YOOR4510	2	21	1B03	
119836-77710	STARTER ASSY	YOOR4510	18	4	1C04	121450-42450	PLUG M16	YOOR4510	10	27	1B11	
119836-77721	COVER ASSY, REAR	YOOR4510	18	5	1C04	121465-59950	BOLT M 6X 16, PLATED	YOOR4510	13	74	1B14	
119836-77730	COVER, REAR	YOOR4510	18	6	1C04	121520-01851	GASKET, (NON-ASB.)	YOOR4510	15	1	1C01	
119836-77741	BRUSH ASSY, REGULATOR	YOOR4510	18	7	1C04					20	24	1C06
119836-77750	BRUSH ASSY	YOOR4510	18	8	1C04	121550-49111	JOINT PT1/4	YOOR4510	10	26	1B11	
119836-77760	GUIDE, FAN SIDE	YOOR4510	18	9	1C04	121575-66830	SCREW, ADJUST	YOOR4510	13	111	1B14	
119836-77770	DIODE ASSY	YOOR4510	18	10	1C04	121750-49150	PIPE, C. WATER	YOOR4510	11	40	1B12	
119836-77780	CONDENSER	YOOR4510	18	11	1C04	121750-59890	RETAINER	YOOR4510	19	38	1C05	
119836-77790	COVER ASSY, FRONT	YOOR4510	18	15	1C04					40	1C05	
119836-77800	RETAINER, BEARING	YOOR4510	18	16	1C04					41	1C05	
119836-77810	PULLEY	YOOR4510	18	19	1C04					42	1C05	
119836-77820	NUT ASSY, PULLEY	YOOR4510	18	20	1C04	121855-13821	SPACER(A)	YOOR4510	6	18	1B07	
119836-77830	BOLT, THROUGH	YOOR4510	18	21	1C04	121855-13830	SPACER(B)	YOOR4510	6	19	1B07	
119836-77840	BALL BEARING	YOOR4510	18	17	1C04	123500-13840	SPACER(C)	YOOR4510	6	20	1B07	
119836-77850	BALL BEARING	YOOR4510	18	3	1C04	124060-01050	PLUG PT1/8	YOOR4510	1	5	1B02	
119836-77860	SCREW KID	YOOR4510	18	18	1C04	124060-21600	GEAR, RING	YOOR4510	8	24	1B09	
119836-77871	BOLT (1)	YOOR4510	18	12	1C04	124060-59380	PLUG	YOOR4510	15	25	1C01	

PART NO.	DESCRIPTION	CATALOG NO.	GRP. NO.	REF. NO.	LOC. NO.	PART NO.	DESCRIPTION	CATALOG NO.	GRP. NO.	REF. NO.	LOC. NO.
124066-59100	CLAMP 8	Y00R4510	14	36	1B16	144626-91560	TACHO UNIT	Y00R4510	9	32	1B10
124085-02220	SEAL, OIL	Y00R4510	3	13	1B04	170064-67210	LABEL, HANDLE	Y00R4510	16	22	1C02
124160-01751	CAP, LUB.OIL SUPPLY	Y00R4510	2	12	1B03	171002-66830	SCREW, ADJUST	Y00R4510	13	112	1B14
			4	56	1B05	171008-03990	CLAMP 25	Y00R4510	9	38	1B10
124160-11360	KNOB	Y00R4510	4	54	1B05	171010-77850	THERMOMETER, C.W.	Y00R4510	19	14	1C05
124160-39450	SWITCH, OIL PRESSURE	Y00R4510	9	28	1B10	171048-67010	REGULATOR ASSY	Y00R4510	16	7	1C02
124190-77110	ARMATURE, (NON-ASB.)	Y00R4510	17	19	1C03	171048-67130	LEVER	Y00R4510	16	16	1C02
124190-77760	PINION ASSY	Y00R4510	17	20	1C03	171048-67140	STOPPER	Y00R4510	16	17	1C02
124250-49351	THERMOMETER	Y00R4510	10	31	1B11	171056-49120	PLUG, DRAIN	Y00R4510	10	14	1B11
124450-44510	TANK	Y00R4510	11	23	1B12	171059-55600	STRAINER ASSY, FUEL	Y00R4510	15	4	1C01
124450-44530	CAP	Y00R4510	11	25	1B12	171080-91100	TACHOMETER	Y00R4510	19	19	1C05
124450-44550	CLAMP, SUB-TANK	Y00R4510	11	28	1B12	171082-91100	TACHOMETER	Y00R4510	19	20	1C05
124450-44560	CLAMP	Y00R4510	11	26	1B12	171085-67100	BRACKET, GEAR	Y00R4510	16	13	1C02
124465-44950	GASKET 16	Y00R4510	10	29	1B11	171085-67110	SHAFT, DRIVING	Y00R4510	16	14	1C02
				30	1B11	171085-67120	GEAR	Y00R4510	16	15	1C02
			20	21	1C06	171090-91010	GAUGE, PRESSURE	Y00R4510	19	17	1C05
124550-55700	ELEMENT, FUEL	Y00R4510	15	13	1C01	171102-66080	SPACER	Y00R4510	16	8	1C02
124550-66370	LOCK NUT M 6	Y00R4510	13	68	1B14	171375-39600	DAMPER ASSY	Y00R4510	9	29	1B10
124550-77030	COVER, TERMINAL	Y00R4510	19	1	1C05	174307-51700	SHIM SET	Y00R4510	13	31	1B14
124559-77971	LAMP, PILOT	Y00R4510	19	16	1C05	194180-51640	CLAMP, WIRE HARNESS	Y00R4510	19	39	1C05
124664-13580	CLAMP	Y00R4510	6	16	1B07	194990-22050	NUT W/WASHER 8	Y00R4510	2	33	1B03
124700-44740	FAN, COOLING	Y00R4510	10	19	1B11				6	5	1B07
124701-91140	CABLE L= 985	Y00R4510	19	3	1C05					27	1B07
124732-77720	LAMP, CHARGING	Y00R4510	19	13	1C05					13	1
124766-59050	CLAMP 12	Y00R4510	11	42	1B12	22111-060000		Y00R4510	13	124	1B15
			15	30	1C01	22117-040000	WASHER 4	Y00R4510	13	51	1B14
				34	1C01	22117-050000	WASHER 5	Y00R4510	19	27	1C05
124770-91220	COVER 52	Y00R4510	19	22	1C05					28	1C05
126650-66020	HANDLE, REGULATOR	Y00R4510	16	4	1C02	22117-100000	WASHER 10	Y00R4510	16	23	1C02
128300-77920	TIMER	Y00R4510	19	15	1C05	22137-040000	WASHER 4, POLISHED	Y00R4510	12	43	1B13
129100-01580	PARALLEL PIN 8X16	Y00R4510	3	1	1B04	22137-080000	WASHER 8, POLISHED	Y00R4510	11	13	1B12
			8	2	1B09	22190-060002	SEAL WASHER 6S	Y00R4510	15	26	1C01
129100-61930	NUT, CAP	Y00R4510	13	63	1B14	22190-060003	WAHER 6, SEAL	Y00R4510	13	114	1B14
129122-44480	JOINT	Y00R4510	9	41	1B10	22190-080002	SEAL WASHER 8S	Y00R4510	15	18	1C01
				42	1B10					19	1C01
129150-35350	NUT	Y00R4510	9	24	1B10					22	1C06
129150-49080	COCK, DRAIN	Y00R4510	11	36	1B12	22190-120002	SEAL WASHER 12S	Y00R4510	13	115	1B14
129150-49100	COCK ASSY, 3-WAY	Y00R4510	11	35	1B12	22217-040000	SPRING WASHER 4	Y00R4510	12	44	1B13
129150-49360	GASKET 10	Y00R4510	10	32	1B11	22217-050000	SPRING WASHER 5	Y00R4510	14	63	1B05
129150-59120	RETAINER, INJ. PIPE	Y00R4510	14	18	1B16	22217-100000	SPRING WASHER 10	Y00R4510	11	14	1B12
129150-59131	BOLT M4X14, HEX. SCKT.	Y00R4510	14	21	1B16					16	24
129150-77340	SPACER	Y00R4510	18	23	1C04	22242-000100	CIRCLIP 10	Y00R4510	4	50	1B05
129150-91400	GEAR UNIT, TACHOMETER	Y00R4510	2	35	1B03	22242-000200	CIRCLIP 20	Y00R4510	7	15	1B08
129155-51280	O-RING S6	Y00R4510	13	16	1B14	22252-000200	CIRCLIP 20	Y00R4510	8	36	1B09
129155-51580	O-RING	Y00R4510	14	2	1B16	22272-000040	CIRCLIP E- 4	Y00R4510	13	52	1B14
129155-61480	SPACER ASSY	Y00R4510	13	23	1B14	22272-000050	CIRCLIP E- 5	Y00R4510	16	25	1C02
129350-49530	COVER, THERMOSTAT	Y00R4510	10	22	1B11	22351-020006	SPRING PIN 2X 6	Y00R4510	16	18	1C02
129350-49541	GASKET, (NON-ASB.)	Y00R4510	10	23	1B11	22351-030014	SPRING PIN 3X14	Y00R4510	13	53	1B14
			20	20	1C06	22351-040010	SPRING PIN 4X10	Y00R4510	2	22	1B03
129350-49800	THERMOSTAT (71°C)	Y00R4510	10	24	1B11					13	60
129400-92400	FLEX HORN	Y00R4510	20	26	1C06	22351-060012	SPRING PIN 6X12	Y00R4510	4	69	1B05
129403-49050	PIPE, COOLER-C.W.PUMP	Y00R4510	9	44	1B10	22360-040000	SNAP PIN 4	Y00R4510	13	116	1B15
129470-39610	DAMPER	Y00R4510	9	30	1B10	22360-060000	SNAP PIN 6	Y00R4510	13	117	1B15
129795-77800	PLUG, GLOW	Y00R4510	4	67	1B05	22411-200150	COTTER PIN 2.0X15	Y00R4510	16	19	1C02

PART NO.	DESCRIPTION	CATALOG NO.	GRP. NO.	REF. NO.	LOC NO.	I	PART NO.	DESCRIPTION	CATALOG NO.	GRP. NO.	REF. NO.	LOC. NO.
22512-040120	KEY 4X 12	YOOR4510	7	8	1B08	I	26106-060402	BOLT M 6X 40 PLATED	YOOR4510	2	9	1B03
				22	1B08	I				6	26	1B07
			8	6	1B09	I	26106-060452	BOLT M 6X 45 PLATED	YOOR4510	3	22	1B04
23010-038000	CLAMP 38	YOOR4510	11	34	1B12	I	26106-060502	BOLT M 6X 50 PLATED	YOOR4510	2	10	1B03
23061-070230	PIPE 7X 230	YOOR4510	11	27	1B12	I	26106-060652	BOLT M 6X 65 PLATED	YOOR4510	2	11	1B03
23065-120500	PIPE, VINYL 12X 500	YOOR4510	4	1	1B05	I	26106-060702	BOLT M 6X 70 PLATED	YOOR4510	13	118	1B15
23161-020100	BUSH PT1/4X1/8	YOOR4510	9	31	1B10	I	26106-060752	BOLT M 6X 75 PLATED	YOOR4510	13	119	1B15
23414-140000	GASKET 14, ROUND	YOOR4510	14	41	1B16	I	26106-060952	BOLT M 6X 95 PLATED	YOOR4510	13	73	1B14
			20	23	1C06	I	26106-080122	BOLT M 8X 12 PLATED	YOOR4510	5	16	1B06
23418-060000	GASKET 6, NYLON	YOOR4510	15	15	1C01	I				11	15	1B12
23871-020000	PLUG PT1/4, SCREW	YOOR4510	4	17	1B05	I				19	36	1C05
24101-062034	BALL BEARING	YOOR4510	7	24	1B08	I	26106-080142	BOLT M 8X 14 PLATED	YOOR4510	4	8	1B05
24102-063034	BALL BEARING 6303U	YOOR4510	7	23	1B08	I					9	1B05
24311-000120	O-RING 1A P 12.0	YOOR4510	2	6	1B03	I	26106-080162	BOLT M 8X 16 PLATED	YOOR4510	11	16	1B12
			4	66	1B05	I					43	1B12
			9	26	1B10	I				16	28	1C02
			20	3	1C06	I	26106-080182	BOLT M 8X 18 PLATED	YOOR4510	18	26	1C04
24311-000180	O-RING 1A P-18.0	YOOR4510	3	20	1B04	I	26106-080202	BOLT M 8X 20 PLATED	YOOR4510	10	25	1B11
			20	7	1C06	I				11	17	1B12
24311-000210	O-RING 1A P-21.0	YOOR4510	10	11	1B11	I	26106-080252	BOLT M 8X 25 PLATED	YOOR4510	11	18	1B12
24311-000320	O-RING 1A P-32.0	YOOR4510	2	13	1B03	I	26106-080402	BOLT M 8X 40 PLATED	YOOR4510	6	6	1B07
			4	64	1B05	I	26106-080452	BOLT M 8X 45 PLATED	YOOR4510	4	52	1B05
			20	4	1C06	I				10	15	1B11
24311-240100	O-RING 1A P-10A	YOOR4510	9	36	1B10	I	26106-080552	BOLT M 8X 55 PLATED	YOOR4510	6	21	1B07
			15	17	1C01	I	26106-081052	BOLT M 8X105 PLATED	YOOR4510	18	22	1C04
24321-000600	O-RING 1A 8-60.0	YOOR4510	9	45	1B10	I	26106-100202	BOLT M10X 20 PLATED	YOOR4510	11	3	1B12
			20	17	1C06	I	26106-100502	BOLT M10X 50 PLATED	YOOR4510	19	37	1C05
24321-000700	O-RING 1A 6-70.0	YOOR4510	9	46	1B10	I	26116-050102	BOLT M 5X 10 PLATED	YOOR4510	13	120	1B15
			20	18	1C06	I				19	29	1C05
24341-000070	O-RING 1A S-7.0	YOOR4510	13	61	1B14	I	26116-060082	BOLT M 6X 8 PLATED	YOOR4510	16	20	1C02
24341-000240	O-RING 1A S-24.0	YOOR4510	2	15	1B03	I	26116-060304	BOLT M 6X 30 PLATED	YOOR4510	13	121	1B15
				37	1B03	I	26116-100202	BOLT M10X 20 PLATED	YOOR4510	3	6	1B04
			20	5	1C06	I	26116-100302	BOLT M10X 30 PLATED	YOOR4510	11	19	1B12
24341-000280	O-RING 1A S-28.0	YOOR4510	13	71	1B14	I	26116-120252	BOLT M12X 25 PLATED	YOOR4510	17	21	1C03
26014-060352	BOLT M 6X 35	YOOR4510	10	20	1B11	I	26206-100252	BOLT M10X25	YOOR4510	3	8	1B04
26014-080702	BOLT W/WASHER M8X 70	YOOR4510	15	27	1C01	I	26216-080222	STUD M 8X 22 PLATED	YOOR4510	6	7	1B07
26022-040082	SCREW M 4X 8	YOOR4510	12	45	1B13	I					8	1B07
26033-060202	SCREW M 6X 20	YOOR4510	19	7	1C05	I	26216-080402	STUD M 8X 40 PLATED	YOOR4510	6	9	1B07
26106-060102	BOLT M 6X 10 PLATED	YOOR4510	3	21	1B04	I	26216-080702	STUD M 8X 70 PLATED	YOOR4510	6	10	1B07
			9	37	1B10	I	26347-040002	U-NUT M 4	YOOR4510	6	22	1B07
			13	62	1B14	I	26347-060002	U NUT 6	YOOR4510	6	23	1B07
			16	26	1C02	I	26366-060002	NUT M 6	YOOR4510	2	34	1B03
26106-060122	BOLT M 6X 12 PLATED	YOOR4510	1	25	1B02	I	26366-080002	NUT M 8	YOOR4510	4	53	1B05
			7	16	1B08	I				6	24	1B07
			9	27	1B10	I				11	20	1B12
26106-060162	BOLT M 6X 16 PLATED	YOOR4510	2	7	1B03	I				18	24	1C04
				38	1B03	I	26450-060202	BOLT M 6X 20	YOOR4510	9	12	1B10
			5	3	1B06	I	26557-040352	SCREW M 4X 35	YOOR4510	6	25	1B07
			7	25	1B08	I	26557-050102	SCREW M 5X 10	YOOR4510	4	65	1B05
			15	3	1C01	I	26587-040102	SCREW M 4X 10	YOOR4510	12	46	1B13
26106-060182	BOLT M 6X 18 PLATED	YOOR4510	2	16	1B03	I	26587-080102	SCREW M 8X 10	YOOR4510	7	26	1B08
26106-060222	BOLT M 6X 22 PLATED	YOOR4510	3	14	1B04	I	26657-100002	CAP NUT M10	YOOR4510	16	27	1C02
26106-060282	BOLT M 6X 28 PLATED	YOOR4510	5	4	1B06	I	26716-050002	NUT M 5	YOOR4510	19	30	1C05
26106-060302	BOLT M 6X 30 PLATED	YOOR4510	2	8	1B03	I	26716-100002	NUT M10	YOOR4510	11	21	1B12

PART NO.	DESCRIPTION	CATALOG NO.	GRP. NO.	REF. NO.	LOC. NO.	PART NO.	DESCRIPTION	CATALOG NO.	GRP. NO.	REF. NO.	LOC. NO.
26756-050002	LOCK NUT M 5 PLATED	YOOR4510	16	3	1C02						
26756-060002	LOCK NUT M 6 PLATED	YOOR4510	4	43	1B05						
				49	1B05						
			13	122	1B15						
26756-100002	LOCK NUT M10 PLATED	YOOR4510	11	22	1B12						
26776-120002	LOCK NUT M12 PLATED	YOOR4510	13	110	1B14						
26921-050122	SCREW M 5X 12	YOOR4510	16	21	1C02						
27221-050080	PLUG 5X 8	YOOR4510	4	18	1B05						
27221-060100	PLUG 6X10	YOOR4510	1	11	1B02						
27231-400000	PLUG 40	YOOR4510	1	12	1B02						
27241-100000	PLUG 10	YOOR4510	1	13	1B02						
27241-250000	PLUG 25	YOOR4510	1	14	1B02						
27241-300000	PLUG 30	YOOR4510	1	15	1B02						
27241-350000	PLUG 35	YOOR4510	4	19	1B05						
714250-11570	COTTER ASSY	YOOR4510	4	24	1B05						
719225-51100	F.I.PUMP ASSY	YOOR4510	12	1	1B13						
719260-02870	MAIN BEARING US=0.25	YOOR4510	1	26	1B02						
719260-11650	ARM ASSY, ROCKER	YOOR4510	4	38	1B05						
719260-11660	ARM ASSY, ROCKER	YOOR4510	4	44	1B05						
719260-23600	BEARING, CRANKPIN	YOOR4510	8	43	1B09						
719260-23610	BEARING, PIN U.S=0.25	YOOR4510	8	53	1B09						
719265-01560	BLOCK ASSY, CYLINDER	YOOR4510	1	1	1B02						
719265-92611	GASKET SET	YOOR4510	20	1	1C06						
719489-11650	ARM ASSY, ROCKER	YOOR4510	4	39	1B05						
719489-11660	ARM ASSY, ROCKER	YOOR4510	4	45	1B05						
719620-53700	VALVE ASSY, F.INJECT	YOOR4510	14	1	1B16						
933110-00100	SWITCH ASSY, STARTER	YOOR4510	19	31	1C05						
933110-00301	KEY ASSY	YOOR4510	19	33	1C05						
977770-01212	GASKET, LIQUID	YOOR4510	20	27	1C06						

Silverhorn.CO.UK



YANMAR DIESEL ENGINE CO., LTD.

YANMAR OSAKA PARTS DEPOT

3-27, Chibune 2-chome, Nishiyodogawa-ku,
Osaka 555, Japan
Telex: J65622 Telephone: 06-477-3004
Facsimile: 06-474-6771

OVERSEAS OPERATIONS DIVISION

1-1, 2-chome, Yaesu, Chuo-ku,
Tokyo 104, Japan
Telex: 0222-4733 Telephone: 03-3275-1111
Facsimile: 03-3272-0687 Cable: YANMAR TOKYO

HEAD OFFICE

1-32, Chayamachi, Kita-ku,
Osaka 530, Japan
Cable: YANMAR OSAKA
Telex No. J63436